

FW 190

INSTRUCTION MANUAL



Top Flite Models Champaign, IL
 Ph: (217) 398-8970, Ext. 5
 Fax: (217) 398-7721
 airsupport@top-flite.com

WARRANTY

Top Flite® Model Manufacturing Co. guarantees this kit to be free from defects in both material and workmanship at the date of purchase. This warranty does not cover any component parts damaged by use or modification. **In no case shall Top Flite's liability exceed the original cost of the purchased kit.** Further, Top Flite reserves the right to change or modify this warranty without notice.

In that Top Flite has no control over the final assembly or material used for final assembly, no liability shall be assumed nor accepted for any damage resulting from the use by the user of the final user-assembled product. By the act of using the user-assembled product, the user accepts all resulting liability.

If the buyer is not prepared to accept the liability associated with the use of this product, the buyer is advised to return this kit immediately in new and unused condition to the place of purchase.

To make a warranty claim send
 the defective part or item to
 Hobby Services at this address:

Hobby Services
 3002 N. Apollo Dr. Suite 1
 Champaign IL 61822 USA

Include a letter stating your name, return shipping address, as much contact information as possible (daytime telephone number, fax number, e-mail address), a detailed description of the problem and a photocopy of the purchase receipt. Upon receipt of the package the problem will be evaluated as quickly as possible.

SPECIFICATIONS

Wingspan:	85 in [2160mm]
Wing Area:	1198 sq in [77.3 dm ²]
Weight:	22–24 lb [9980–10880 g]
Wing Loading:	42–46 oz/sq ft [128–140 g/dm ²]
Length:	73-1/4 in [1860mm]
Radio:	7–8 channel
Engine:	50–55 cc gasoline only

READ THROUGH THIS MANUAL BEFORE STARTING CONSTRUCTION. IT CONTAINS IMPORTANT INSTRUCTIONS AND WARNINGS CONCERNING THE ASSEMBLY AND USE OF THIS MODEL.

TABLE OF CONTENTS

INTRODUCTION 2 Academy of Model Aeronautics 2 International Miniature Aircraft Association 2 Scale Competition 3 IMPORTANT SAFETY PRECAUTIONS 3 DECISIONS YOU MUST MAKE 3 Engine Recommendations 3 Radio Equipment 3 Retractable Landing Gear 4 ADDITIONAL ITEMS REQUIRED 4 Required Hardware & Accessories 4 Adhesives & Building Supplies 4 Covering Tools 5 Optional Supplies & Tools 5 IMPORTANT BUILDING NOTES 5 MODEL INSPECTION 5 ORDERING REPLACEMENT PARTS 5 COMMON ABBREVIATIONS 6 CONTENTS 6 ASSEMBLE THE WINGS 7 Mount the Aileron Servos 7 Install the Flap Servos 8	Install the Aileron & Flap Pushrods 8 Mount the Retracts 10 Join the Wings 11 ASSEMBLE THE FUSELAGE 12 Install the Stabilizer 12 Install the Elevator & Rudder Servos 14 Mount the Retractable Tail Gear 14 INSTALL THE ENGINE 17 ASSEMBLE AND INSTALL THE FUEL TANK 20 INSTALL THE AIR RETRACT CONTROLS 21 INSTALL THE COWL 22 APPLY THE FINAL DETAILS 24 Apply the Decals 27 GET THE MODEL READY TO FLY 28 Install the Propeller 28 Balance the Model Laterally 28 Check the Control Directions 28 Set the Control Throws 28 Balance the Model (C.G.) 29 CHECK LIST 30 PREFLIGHT 31 Identify Your Model 31	Charge the Batteries 31 Ground Check & Range Check 31 ENGINE SAFETY PRECAUTIONS 31 AMA SAFETY CODE 31 General 31 Radio Control 32 IMAA SAFETY CODE 32 FLYING 33 Fuel Mixture Adjustments 33 Takeoff 33 Flight 33 Landing 33 Decal Placement Key 34 Landing Gear Cover Template 35 Identification Tag 35
--	--	--

INTRODUCTION

In the late 1930's the German Ministry of Aviation was concerned that in the future the Allies would develop a plane that was better than the Bf 109. They asked the German airplane designers to design a plane to meet this concern. The Fw 190 met these demands. The Fw 190 was considered one of the best German prop planes of WWII. Top Flite developed the Giant FW 190A-3 ARF to get you in the air quickly with a great looking model, without the sanding and covering required to build a kit.

For the latest technical updates or manual corrections to the Giant FW 190A-3 ARF visit the Top Flite web site at www.top-flite.com. Open the "Airplanes" link, then select the Giant FW 190A-3 ARF. If there is new technical information or changes to this model a "tech notice" box will appear in the upper left corner of the page.

ACADEMY OF MODEL AERONAUTICS

If you are not already a member of the AMA, please join! The AMA is the governing body of model aviation and membership provides liability insurance coverage, protects modelers' rights and interests and is required to fly at most R/C sites.

Academy of Model Aeronautics
 5151 East Memorial Drive
 Muncie, IN 47302-9252



Ph. (800) 435-9262
 Fax (765) 741-0057

Or via the Internet at:
<http://www.modelaircraft.org>

IMPORTANT!!! Two of the most important things you can do to preserve the radio controlled aircraft hobby are to avoid flying near full-scale aircraft and avoid flying near or over groups of people.

IMAA

The Top Flite Giant Fw 190A-3 ARF is an excellent sport-scale model and is eligible to fly in IMAA events. The IMAA (International Miniature Aircraft Association) is an organization that promotes non-competitive flying of giant-scale models. If you plan to attend an IMAA event, obtain a copy of the **IMAA Safety Code** by contacting the IMAA at the address or telephone number below, or by logging on to their web site at: www.fly-ima.org/ima/sanction.html.

IMAA
 205 S. Hilldale Road
 Salina, KS 67401
 (913) 823-5569



SCALE COMPETITION

Though the Top Flite Giant Fw 190A-3 is an ARF and may not have the same level of detail as an “all-out” scratch-built competition model, it is a scale model nonetheless and is therefore eligible to compete in the *Fun Scale* class in AMA competition (we receive many favorable reports of Top Flite ARFs in scale competition!). In Fun Scale, the “builder of the model” rule does not apply. To receive the five points for scale documentation, the only proof required that a full size aircraft of this type in this paint/markings scheme did exist is a single sheet such as a kit box cover from a plastic model, a photo, or a profile painting, etc. If the photo is in black and white, other written documentation of color must be provided. Contact the AMA for a rule book with full details.

For more information and scale details of the full-size Fw 190A-3, photo packs are available from:

Bob's Aircraft Documentation

3114 Yukon Ave Ph: (714) 979-8058
Costa Mesa, CA 92626 Fax: (714) 979-7279

e-mail: www.bobsairdoc.com

IMPORTANT SAFETY PRECAUTIONS

PROTECT YOUR MODEL, YOURSELF & OTHERS... FOLLOW THESE IMPORTANT SAFETY PRECAUTIONS

1. Your Giant Fw 190A-3 ARF should not be considered a toy, but rather a sophisticated, working model that functions very much like a full-size airplane. Because of its performance capabilities, the Giant Fw 190A-3 ARF, if not assembled and operated correctly, could possibly cause injury to yourself or spectators and damage to property.

2. You must assemble the model **according to the instructions**. Do not alter or modify the model, as doing so may result in an unsafe or unflyable model. In a few cases the instructions may differ slightly from the photos. In those instances the written instructions should be considered as correct.

3. You must take time to **build straight, true and strong**.

4. You must use an R/C radio system that is in good condition, a correctly sized engine, and other components as specified in this instruction manual. All components must be correctly installed so that the model operates correctly on the ground and in the air. You must check the operation of the model and all components before **every** flight.

5. If you are not an experienced pilot or have not flown this type of model before, we recommend that you get the assistance of an experienced pilot in your R/C club for your first flights. If you're not a member of a club, your local hobby shop has information about clubs in your area whose membership includes experienced pilots.

6. While this kit has been flight tested to exceed normal use, if the plane will be used for extremely high stress flying, such as racing, or if an engine larger than one in the recommended range is used, the modeler is responsible for taking steps to reinforce the high stress points and/or substituting hardware more suitable for the increased stress.

7. **WARNING:** The cowl and landing gear covers included in this kit are made of fiberglass, the fibers of which may cause eye, skin and respiratory tract irritation. Never blow into a part to remove fiberglass dust, as the dust will blow back into your eyes. Always wear safety goggles, a particle mask and rubber gloves when grinding, drilling and sanding fiberglass parts. Vacuum the parts and the work area thoroughly after working with fiberglass parts.

We, as the kit manufacturer, provide you with a top quality, thoroughly tested kit and instructions, but ultimately the quality and flyability of your finished model depends on how you build it; therefore, we cannot in any way guarantee the performance of your completed model, and no representations are expressed or implied as to the performance or safety of your completed model.

REMEMBER: Take your time and follow the instructions to end up with a well-built model that is straight and true.

DECISIONS YOU MUST MAKE

This is a partial list of items required to finish the Giant Fw 190A-3 ARF that may require planning or decision making before starting to build. Order numbers are provided in parentheses.

ENGINE RECOMMENDATIONS

When considering engines for this model, refer to the engine size recommendations on the cover of the manual. Spark-ignition “gas” engines are most popular with large-scale warbirds such as this. One advantage of a gas engine is economy – gas engines tend to consume less fuel than a glow engine as well. Additionally, gas engines deposit little exhaust residue on the model. Among other engines, this model was test flown with a **DLE-55** engine. The DLE-55 and the O.S.[®] GT55 both provide more than adequate power and fly the Giant Fw 190A-3 ARF in a scale-like manner.

Note: Instructions for mounting every possible engine cannot be incorporated into this manual. Modelers using another engine may refer to the instructions as a guide for mounting their engine in a similar way. If using the DLE-55 engine, the stock muffler will work well and is recommended.

Hardware required (not included) to mount the DLE-55 engine.

- (4) 10-32 x 1-1/2" Socket head cap screws
- (4) #10 Lock washers
- (4) #10 Fender washers

Per the IMAA Safety Code, magneto spark-ignition engines must have a coil-grounding switch on the aircraft to stop the engine and prevent accidental starting. The switch must be operated manually (without the use of the transmitter) and accessible by the pilot and assistant.

RADIO EQUIPMENT

The radio equipment and number of channels required to fly the Top Flite Giant Fw 190A-3 ARF depend on the capabilities of your transmitter and how the servos will be connected.

The Giant Fw 190A-3 ARF requires a servo to operate the air control valve, a servo to retract the tail gear, a servo to steer the tail gear, a throttle servo, two flap servos, two aileron servos, two elevator servos and a rudder servo. Servos with a minimum of 50 oz-in [3.9kg-cm] of torque are required for operating the elevators, rudder, ailerons and flaps. We recommend that metal geared servos also be used. Standard servos may be used for the throttle and choke (the servo operated choke is optional). A micro servo is required to operate the retract air valve. An optional servo-operated kill switch may also be used (this is in addition to the IMAA-required, manually operated engine kill switch). A servo operated kill switch is only really necessary for engines that do not reliably shut off by closing the carburetor, but could also serve as a backup.

Function	Servos required
Elevators	2 (min. 50 oz-in torque) (Futaba® S3305 FUTM0045)
Rudder	1 (min. 50 oz-in torque) (Futaba S3305 FUTM0045)
Ailerons	2 (min. 50 oz-in torque) (Futaba S3305 FUTM0045)
Flaps	2 (min. 50 oz-in torque) (Futaba S3305 FUTM0045)
Tail Steering	1 (min. 50 oz-in torque) (Futaba S3305 FUTM0045)
Tail Gear Retract	1 (min. 50 oz-in torque) (Futaba S3305 FUTM0045)
Throttle	1 (standard) (Futaba S9001 FUTM0075)
Retract	1 (micro) (Futaba S3102 FUTM0034)
Optional Choke	1 (standard) (Futaba S9001 FUTM0075)

Total 11-12 servos

A receiver battery with a minimum of 4.8V 2,400mAh is recommended for flying the Giant Fw 190A-3 ARF. The battery voltage should be checked before every flight to be certain it has enough “charge”.

In addition to the servos, the following items (or similar items) are also required. The order numbers shown in parentheses are for Futaba servos.

- (4) 6" Y-harness for elevator, rudder/steering, ailerons and flaps (FUTM4135)
- (2) 12" [305mm] servo extension for flaps (HCAM2711)
- (2) 24" [610mm] servo extension for ailerons (HCAM2721)
- (2) Heavy Duty switch harness (FUTM4385)
- (2) Ernst Charge Receptacle 124 (ERNM3001)
- (1) HydriMax™ 3600mAh NiMH battery (HCAM6333) for receiver
- (1) HydriMax 1600mAh NiMH battery (HCAM6308) for engine ignition

Note: The length and quantity of servo extensions and Y-connectors may vary depending on the brand of radio you are using and the radio installation.

RETRACTABLE LANDING GEAR

The Top Flite Giant Fw 190A-3 ARF has been designed for Robart pneumatic and electric main gear retracts and mechanical tail gear. The tail gear on the full size Fw 190A-3 did not retract fully into the fuselage. To obtain the scale retraction of the tail gear, a mechanical retract was used. Following is the complete list of items required to install the Robart retracts:

- (1) Robart TFFW190 Top Flite Giant Fw 190 pneumatic retractable main landing gear (ROBQ1658)
- (1) Robart TFFW190E Top Flite Giant Fw 190 electric retractable main landing gear (ROBQ1657)
- (1) Robart #160 retractable tail gear assembly (ROBQ2220)
- (1) Robart #157VRX Large-Scale Deluxe Air Control Kit – includes pressure tank, air line tubing, variable-rate air valve, T-fittings (ROBQ2305)

- (1) Robart #169 10' [3048mm] red & purple Pressure tubing (ROBQ2369)
- (1 pkg.) #190 Air Line Quick Disconnects (ROBQ2395)

Note: An air pump will also be required to pressurize the air tank. The Robart hand pump could be used, but is not practical because of the large capacity of the air tank in this model. A small, 12V electric pump is recommended and can be purchased at any automotive or hardware store.

ADDITIONAL ITEMS REQUIRED

REQUIRED HARDWARE & ACCESSORIES

In addition to the items listed in the “*Decisions You Must Make*” section, following is the list of hardware and accessories required to finish the Top Flite Giant FW 190A-3 ARF. Order numbers are provided in parentheses.

- (2) Dubro #813 1/8" Fuel Line Barb (DUBQ0670)
- (1) Dubro #554 X-large Tygon Fuel Line (DUBQ0427)
- (1) R/C foam rubber (1/4" [6mm] (HCAQ1000) or 1/2" [13mm] (HCAQ1050)
- Propeller and spare propellers suitable for your engine.
- (1) Painted Pilot (We used the 1/5 scale German Pilot from *Aces of Iron Productions*)
- (1) 7/64" – 10" [254mm] long Ball-end Hex Wrench
OR
○ (1) 7/64" Ball-end Hex Wrench (GPMR8003) plus (1) 5/32" x .014 Round Brass Tube K&S #128 (K+SR2628) (See Page 35)

ADHESIVES AND BUILDING SUPPLIES

This is the list of Adhesives and Building Supplies that are required to finish the Giant FW 190A-3 ARF.

- 1/2 oz. [15g] Thin Pro™ CA (GPMR6001)
- 1/2 oz. [15g] Medium Pro CA+ (GPMR6007)
- Pro 30-minute epoxy (GPMR6047)
- Pro 6-minute epoxy (GPMR6045)

- Threadlocker thread locking cement (GPMR6060)
- Mixing sticks (50) (GPMR8055)
- Mixing cups (50) (GPMR8056)
- Epoxy brushes (6) (GPMR8060)
- Denatured alcohol (for epoxy clean up)
- R/C-56 canopy glue (JOZR5007)
- Milled fiberglass (GPMR6165)
- Masking tape
- Plan protector (GPMR6167) or wax paper
- Drill
- Drill bits: 1/16" [1.6mm], 5/64" [2mm], 3/32" [2.4mm], 1/8" [3.2mm], 3/16" [4.8mm], 13/64" [5.2mm], 1/4" [6.4mm]
- Small metal file
- Stick-on segmented lead weights (GPMQ4485)
- Silver solder w/flux (STAR2000)
- Hobby Heat™ Micro Torch II (HCAR0755)
- #1 Hobby knife (RMXR6903)
- #11 blades (5-pack, RMXR6930)
- Curved-tip canopy scissors for trimming plastic parts (HCAR0667)

COVERING TOOLS

- Top Flite MonoKote® sealing iron (TOPR2100)
- Top Flite Hot Sock™ iron cover (TOPR2175)
- Top Flite MonoKote trim seal iron (TOPR2200)
- Top Flite MonoKote heat gun (TOPR2000)

OPTIONAL SUPPLIES AND TOOLS

Here is a list of optional tools mentioned in the manual that will help you build the Giant FW 190A-3 ARF.

- 2 oz. [57g] spray CA activator (GPMR6035)
- CA applicator tips (HCAR3780)
- CA debonder (GPMR6039)
- Builder's Triangle Set (HCAR0480)
- Scale Warbird Template (TOPR2187)
- 36" metal ruler (HCAR0475)
- Hobbico® High Precision Diagonal Cutter 5" (HCAR0630)
- Pliers with wire cutter (HCAR0625)

- Robart Super Stand II (ROBP1402)
- Switch & Charge Jack Mounting Set (GPMM1000)
- Panel Line Pen (TOPQ2510)
- Rotary tool such as Dremel
- Rotary tool reinforced cut-off wheel (GPMR8200)
- Servo horn drill (HCAR0698)
- AccuThrow™ Deflection Gauge (GPMR2405)
- CG Machine™ (GPMR2400)
- Precision Magnetic Prop Balancer (TOPQ5700)

IMPORTANT BUILDING NOTES

- Anytime a sheet metal screw is installed in wood, first install the screw, remove the screw and apply a couple of drops of thin CA in the hole to harden the threads. After the CA has cured, reinstall the screw.
- **Photos** and **sketches** are placed **before** the step they refer to. Frequently you can study photos in following steps to get another view of the same parts.
- The Giant FW 190A-3 ARF is factory-covered with Top Flite MonoKote film. Should repairs ever be required, MonoKote can be patched with additional MonoKote purchased separately. MonoKote is packaged in six-foot rolls, but some hobby shops also sell it by the foot. If only a small piece of MonoKote is needed for a minor patch, perhaps a fellow modeler would give you some. MonoKote is applied with a model airplane covering iron, but in an emergency a regular iron could be used. A roll of MonoKote includes full instructions for application. Following are the colors used on this model and order numbers for six foot rolls.
 - White (TOPQ0204)
 - CubYellow (TOPQ0220)
 - Flat Black (TOPQ0508)
 - Flat Olive Drab (TOPQ0510)
 - Flat Dove Gray (TOPQ0511)
- The stabilizer and wing incidences and engine thrust angles have been factory-built into this model. However, some technically-minded modelers may wish to check these measurements anyway. To view this information visit the web site at www.top-flite.com

and click on "Technical Data." Due to manufacturing tolerances which will have little or no effect on the way your model will fly, please expect slight deviations between your model and the published values.

MODEL INSPECTION

Before starting to build, take an inventory of this model to make sure it is complete, and inspect the parts to make sure they are of acceptable quality. If any parts are missing or are not of acceptable quality, or if you need assistance with assembly, contact **Product Support**. When reporting defective or missing parts, use the part names exactly as they are written in the instruction manual.

Top Flite Product Support

3002 N Apollo Drive, Suite 1
Champaign, IL 61822

Ph: (217) 398-8970, ext. 5 Fax: (217) 398-7721
E-mail: productsupport@top-flite.com

ORDERING REPLACEMENT PARTS

Replacement parts for the Top Flite Giant FW 190A-3 ARF are available using the order numbers in the **Replacement Parts List** that follows. The fastest, most economical service can be provided by your hobby dealer or mail-order company. Not all parts are available separately (an aileron cannot be purchased separately, but is only available with the wing kit). Replacement parts are not available from Product Support, but can be purchased from hobby shops or mail order/Internet order firms. Hardware items (screws, nuts, bolts) are also available from these outlets.

To locate a hobby dealer, visit www.top-flite.com and click on "Where to Buy". Follow the instructions provided on the page to locate a U.S., Canadian or International dealer.

Parts may also be ordered directly from Hobby Services by calling (217) 398-0007, or via facsimile at (217) 398-7721, but full retail prices and shipping and handling charges will apply. Illinois and Nevada residents will also be charged sales tax. If ordering via fax, include a Visa® or MasterCard® number and expiration date for payment.

Mail parts orders **Hobby Services**
 and payments by 3002 N Apollo Drive, Suite 1
 personal check to: Champaign IL 61822

Be certain to specify the order number exactly as listed
 in the **Replacement Parts List**. Payment by credit card
 or personal check only; no C.O.D.

If additional assistance is required for any reason
 contact **Product Support**

by e-mail at productsupport@top-flite.com **or by telephone at**
 (217) 398-8970

REPLACEMENT PARTS LIST

Order No.	Description
TOPA1870	Wing
TOPA1871	Fuselage
TOPA1872	Horizontal Stabilizer
TOPA1873	Rudder
TOPA1874	Canopy
TOPA1875	Cowl
TOPA1876	Landing Gear Covers
TOPA1877	Hatch
TOPA1878	Tail Gear Cover
TOPA1879	Decals
TOPA1880	Cockpit Kit
TOPA1881	Spinner 2 blade
TOPA1882	Spinner 3 blade

COMMON ABBREVIATIONS

Stab = Horizontal Stabilizer
 Fin = Vertical Stabilizer
 LE = Leading Edge
 TE = Trailing Edge
 " = Inches
 mm = millimeters
 SHCS = Socket Head Cap Screw

To convert inches to millimeters, multiply inches by 25.4
 (25.4mm = 1")

CONTENTS

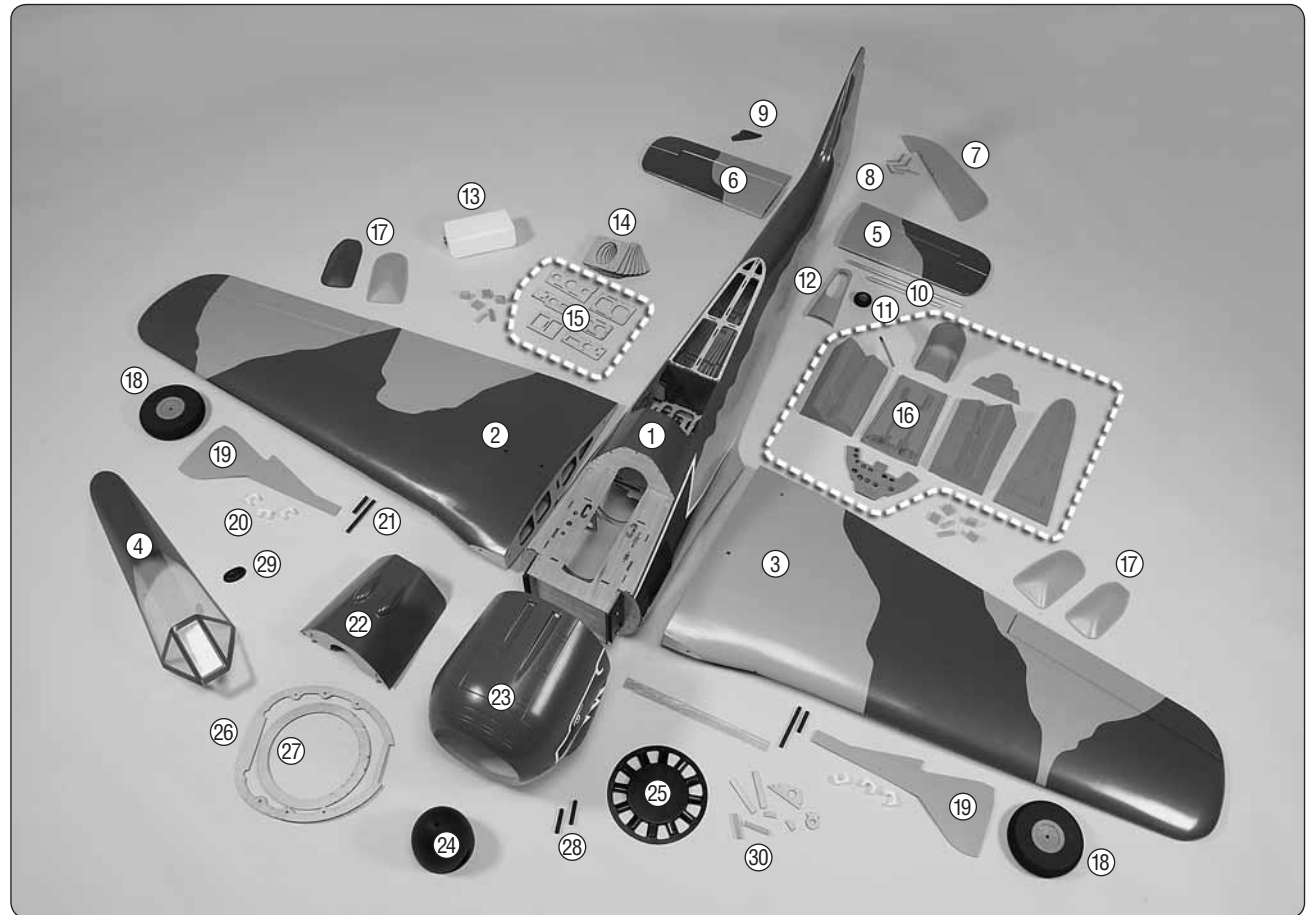

- | | |
|------------------------------------|------------------------------|
| 1. Fuselage | 16. Cockpit Interior |
| 2. Right Wing Half | 17. Gun Covers |
| 3. Left Wing Half | 18. Wheel |
| 4. Canopy | 19. Landing Gear Doors |
| 5. Left Horizontal Stabilizer | 20. Landing Gear Door Mounts |
| 6. Right Horizontal Stabilizer | 21. Guns |
| 7. Rudder | 22. Forward Hatch |
| 8. Hinges | 23. Cowl |
| 9. Vertical Fin Antenna Mount | 24. Spinner |
| 10. Aluminum Stabilizer Tubes | 25. Plastic Fan |
| 11. Tail Wheel | 26. Cowl Ring |
| 12. Tail Gear Retract Cover | 27. Fan Ring |
| 13. Fuel Tank | 28. Cowl Guns |
| 14. Engine Spacers | 29. Canopy Antenna Mount |
| 15. Throttle Servo/Rx Battery Tray | 30. Wing Dowels |

ASSEMBLE THE WINGS

Important: If you remove all the parts from the plastic bags, save the plastic bag the cowl comes in. The bag will be used later when the cowl is installed.

Start with the left wing so the assembly matches the photos the first time through.

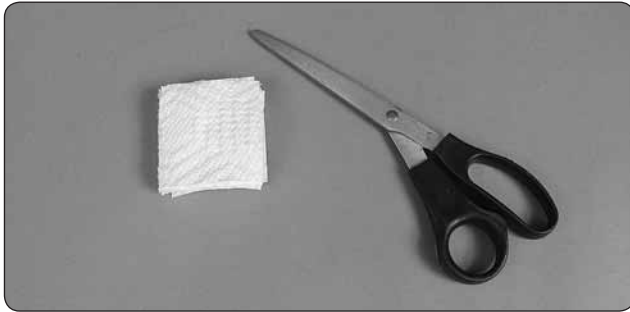

1. Lay a few paper towels on top of each other and cut them into small squares. These paper towel squares will come in handy for wiping away excess epoxy throughout the assembly process (and will save you from wasting whole paper towels).



2. If necessary, use a covering iron with a covering sock to go over the wing, flap and aileron to remove any wrinkles. The best method to remove the wrinkles is to glide the iron over the covering until the wrinkles disappear, then go over the area again, pushing down on the iron to bond the covering to the wood. If the wrinkles don't disappear, the balsa in that area might

be flexing inward. If this is happening, don't press down. Simply let the heat of the iron shrink the covering. If the wrinkles momentarily disappear, then immediately reappear, the iron may be too hot, thus causing air bubbles. Lower the temperature of the iron or use a sharp #11 blade or pin to puncture several holes in the covering, then reheat. The suggested iron temperature is around 360 degrees F.



The Focke-Wulf FW 190 was designed by Kurt Tank in the late 1930's. It was used in a wide variety of roles including fighter, fighter-bomber, and ground attack. It was first used on the Eastern Front in Nov/Dec of 1942.

MOUNT THE AILERON SERVOS

1. Carefully remove the left aileron servo hatch from the wing by peeling off the masking tape holding the hatch to the wing. Use a paper towel square dampened with naphtha lighter fluid or similar solvent to remove any glue left behind from the tape.

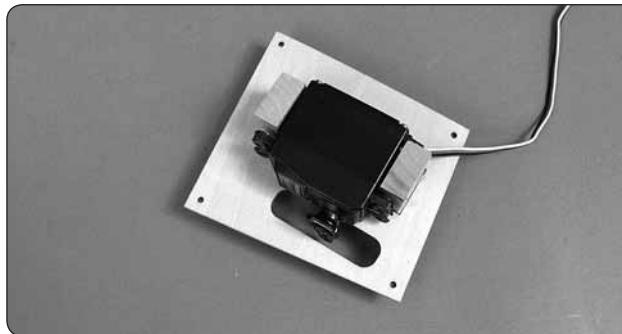

2. Install the rubber bushings and metal grommets in the aileron servo. Install a servo arm on the servo. Position the aileron servo on the aileron servo hatch cover as shown with the servo arm centered in the opening. Set the two 3/4" x 3/4" x 3/8" [19 x 19 x 9.5mm] hardwood blocks over the embossed servo block locations to check that the block locations are correct. If not, mark the new location.



When mounting the servo blocks on the bottom of the servo hatch, make sure that the grain of the wood is perpendicular to the hatch.



To increase the strength of the glue joint, use a T-pin to prick holes into the gluing surface of the servo blocks and the plywood servo hatch. Be careful not to prick holes completely through the servo hatch and covering.

3. Use 6-minute epoxy to glue the two blocks to the bottom of the servo hatch over the embossed servo block locations. Thoroughly coat the end of the blocks and allow them to set for a few seconds to allow the blocks to absorb the epoxy, then recoat the blocks. Use clamps to hold the blocks to the servo hatch.

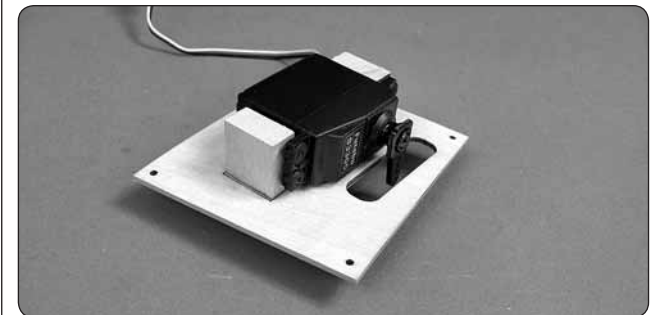

4. Once the epoxy has cured, remove the clamps. Place a 1/16" [1.6mm] spacer, such as a piece of cardstock from a header card or a piece of paper

folded several times, under the servo and between each mounting block. After the servo is installed the spacer will be removed, providing adequate spacing for vibration isolation.

❑❑ 5. Drill 1/16" [1.6mm] holes through the blocks for the servo mounting screws. Mount the servo to the blocks with the screws that came with the servo. Remove the servo mounting screws and apply a couple of drops of thin CA in each hole to harden the threads. Allow the CA to fully harden. Then, reinstall the servos and remove the spacer.

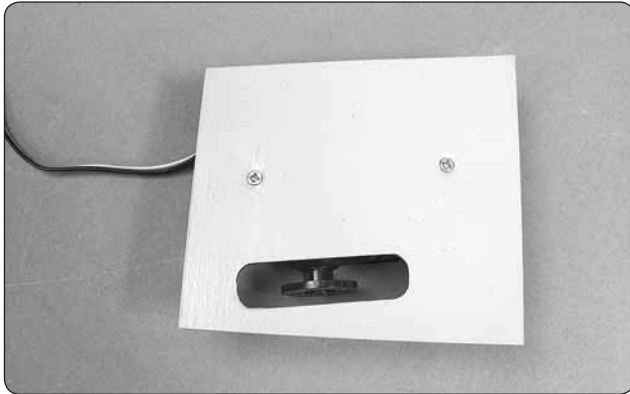

❑❑ 6. Drill 1/16" [1.6mm] holes through the blocks at the two hole locations on the top of the hatch. Install two #2 x 3/8" [9.5mm] flat head sheet metal screws to secure the servo mounting blocks to the aileron servo hatch. Use thin CA to harden the screw threads.

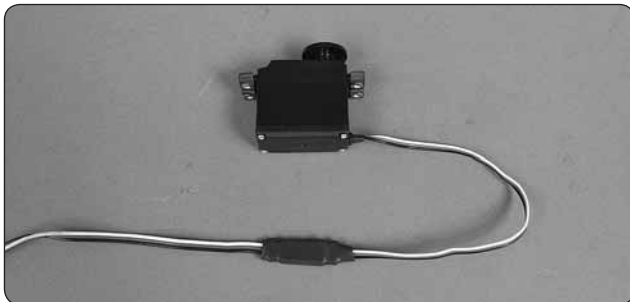

❑❑ 7. Connect a 24" [610mm] servo extension wire (not included) to the aileron servo. Cut a piece of the included heat shrink tubing in half and slide it over the servo connections. Shrink the tubing by applying heat.

❑❑ 8. Use the string in the wing to pull the aileron wire through the wing.

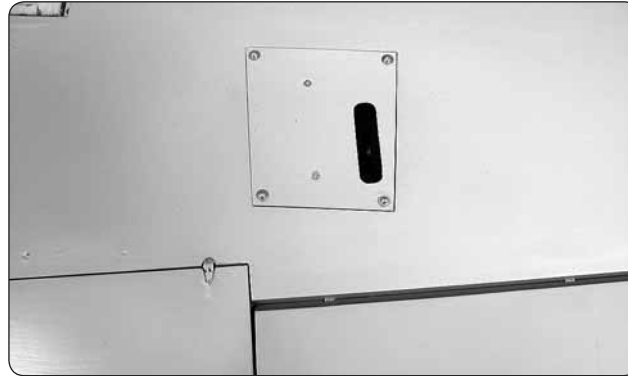

❑❑ 9. Place the aileron servo hatch with the servo in the wing. Be certain that the hatch is positioned correctly as shown. Secure the hatch using four #2 x 3/8" [9.5mm] sheet metal screws and #2 flat washers. Use thin CA to harden the screw threads.

❑❑ 10. Go back to step 1 and install the right aileron servo following the same procedure.

INSTALL THE FLAP SERVOS

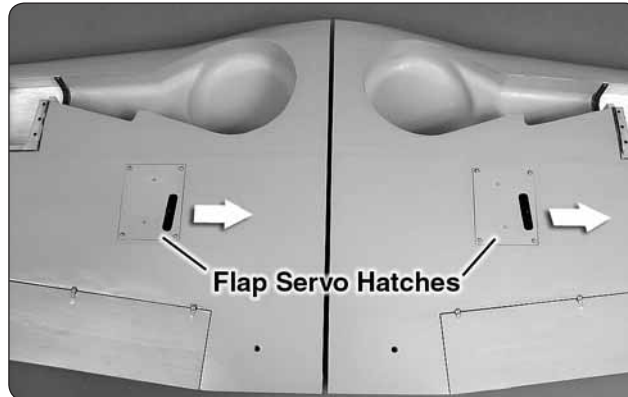

❑❑ 1. Install the flap servos following the same procedure used to install the aileron servos. Note that the flap servos face the same direction.

❑❑ 2. Connect a 12" [304mm] servo extension wire (not included) to the flap servo. Secure the extension to the servo with a piece of heat shrink or electrical tape.

❑❑ 3. Route the flap and aileron servo leads to the root of the wing and out the hole in the top of the wing.

INSTALL THE AILERON & FLAP PUSHRODS

Do the left aileron first. Check that the hinges are secure by pulling on the ailerons and flaps.

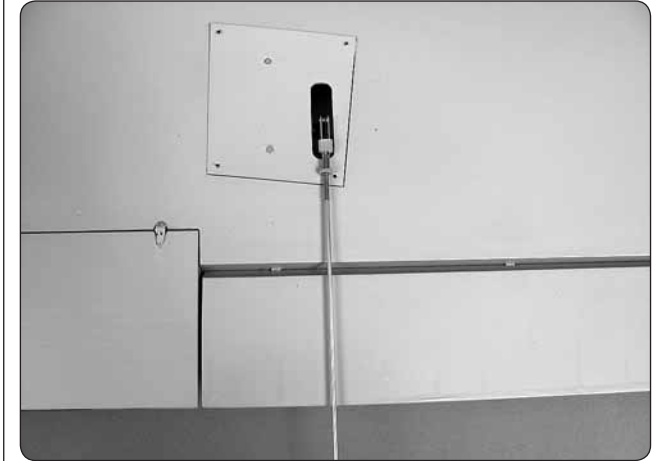

❑❑ 1. Slide a silicone clevis retainer over a 4-40 threaded metal clevis. Thread a 4-40 nut followed by the 4-40 metal clevis, threaded 12 turns onto a 4-40 x 12" [304mm] metal pushrod. Attach the clevis to the aileron servo arm 5/8" [16mm] from the center of the arm.



❑❑ 2. Position the control horn so that it is in line with the pushrod and over the plywood mounting plate. The pushrod holes in the control horn should be aligned

with the hinge line of the aileron. On the aileron, mark the four mounting holes. Remove the control horn and drill a 5/64" [2mm] pilot hole at each mark. **Do not drill completely through the aileron.** Attach the control horn using four #4 x 1/2" sheet metal screws. Use thin CA to harden the holes.

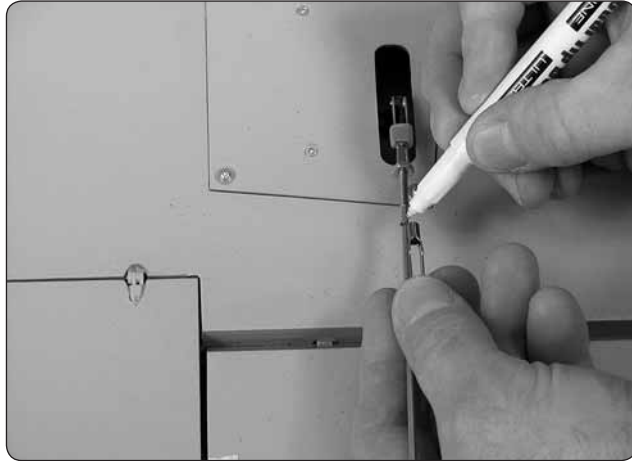

❑ ❑ 3. Install the metal solder clevis in the hole nearest the end of the control horn. Center the aileron servo and aileron. Mark the pushrod where it meets the solder clevis. Remove the pushrod and the solder clevis and cut the pushrod 1/4" [6.4mm] **past** the mark. Solder the solder clevis to the pushrod using the techniques described in the following **Hot Tip**.

Hot Tip

HOW TO SOLDER

1. Roughen the end of the pushrod with coarse sandpaper where it is to be soldered. Use denatured alcohol or other solvent to thoroughly clean the pushrod.

2. Apply a few drops of soldering flux to the end of the pushrod, then use a soldering iron or a torch to heat it. "Tin" the heated area with silver solder by applying the solder to the end. The heat of the pushrod should melt the solder – not the flame of the torch or soldering iron – thus allowing the solder to flow. The end of the wire should be coated with solder all the way around.

3. Place the clevis on the end of the pushrod. Add another drop of flux, then heat and add solder. The same as before, the heat of the parts being soldered should melt the solder, thus allowing it to flow. Allow the joint to cool naturally without disturbing. Avoid excess blobs, but make certain the joint is thoroughly soldered. The solder should be shiny, not rough. If necessary, reheat the joint and allow to cool.

4. Immediately after the solder has solidified, but while it is still hot, use a cloth to quickly wipe off the flux before it hardens. **Important:** After the joint cools, coat the joint with oil to prevent rust. **Note:** Do not use the acid flux that comes with silver solder for electrical soldering.



This is what a properly soldered clevis looks like – shiny solder with good flow, no blobs and flux removed.

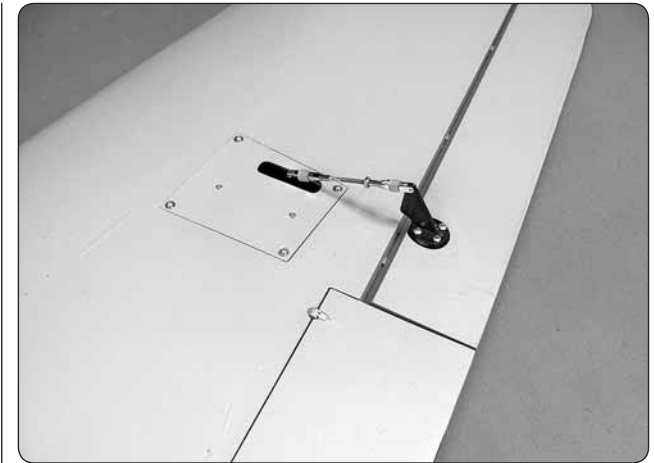

❑ ❑ 4. Slide a silicone clevis retainer over the solder clevis. Reinstall the aileron pushrod with the threaded clevis attached to the control horn. Adjust the threaded clevis so that the aileron is centered. Apply a drop of thread locker to the threads of the pushrod behind the clevis. Tighten the 4-40 nut against the clevis.

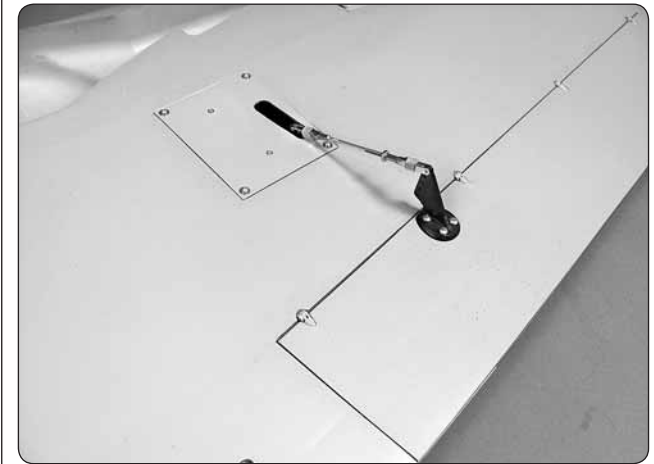

❑ ❑ 5. Assemble and connect the flap pushrod following the same procedure. We installed the pushrod in the outer hole of the control horn and the hole 5/8" [16mm] from the center of the servo arm.

❑ 6. Return to step 1 and install the aileron and flap pushrods on the right wing.



Fw 190 FACT

The FW 190 was designed with a wide landing gear which gave it better ground handling on the rough landing fields used during the war. The landing gear was also raised and lowered electrically, whereas most fighters of that period used hydraulic systems.

MOUNT THE RETRACTS

Install the left retract first.

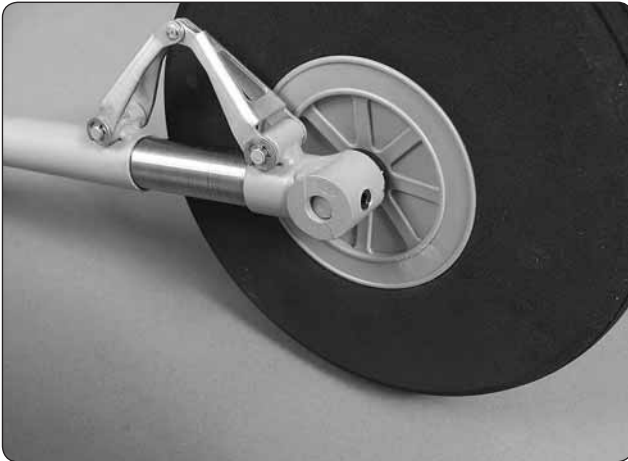
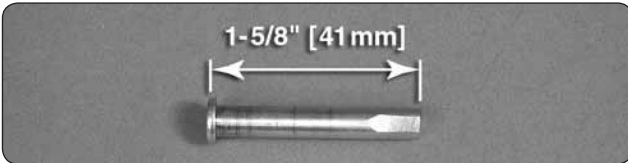

❑❑ 1. Trim the axle that is included with the Robart retracts to 1-5/8" [41mm] long. File a flat spot at the end of the axle. Insert the axle through the included 5-1/4" [133mm] wheel. Slide the 4mm thick wheel spacer onto the axle. Insert the axle into the retract. Apply a drop of threadlocker to the 10-32 x 3/16" [4.8mm] set screw, included with the retract, and tighten the set screw onto the flat of the axle. Make sure that the wheel rotates freely.

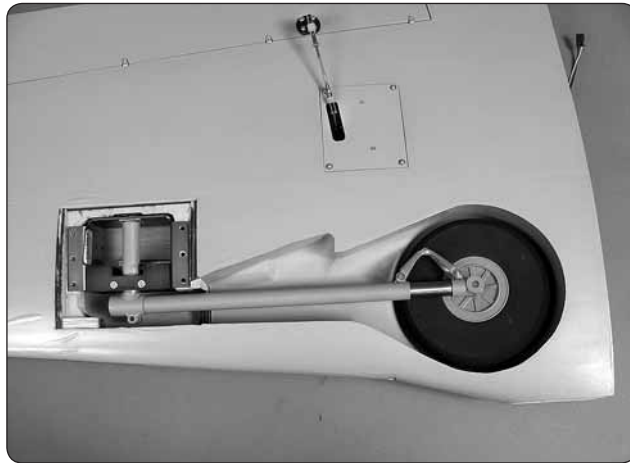

❑❑ 2. Test fit the retract unit with the wheel into the wing. Position the retract so the wheel is centered in the wheel well. Adjust the strut position in the retract body as necessary to achieve the correct spacing all the way around the wheel.

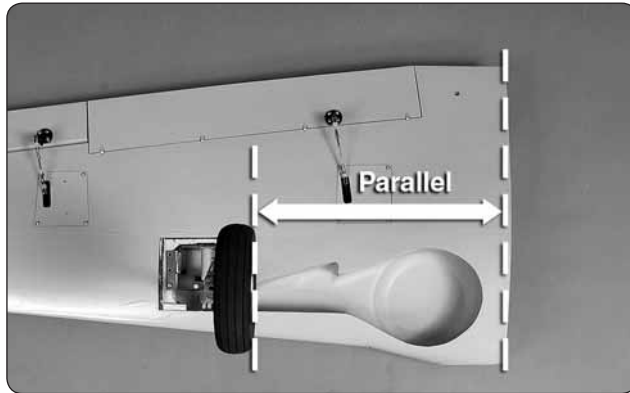

❑❑ 3. Temporarily attach the retract to the wing with two 6-32 x 3/4" [19mm] machine screws. Extend the retract. View the wheel from directly above. Rotate the strut so that the wheel is parallel to the root of the wing. Lock the strut in position by applying a drop of threadlocker to the threads and securely tightening the bolt at the top of the strut.

❑❑ 4. Double check that the wheel will fully retract into the wing. Extend the retract to make sure it does not interfere with any part of the wing and that the retract is operating smoothly.

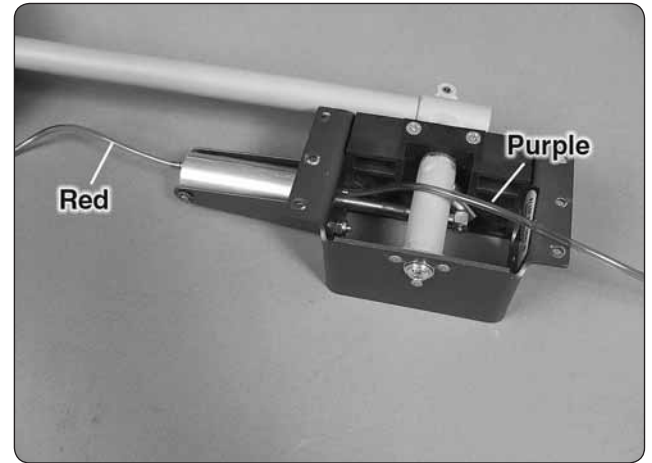

❑❑ 5. Cut an 18" [457mm] piece of red pressure tubing and a 23" [584mm] piece of purple pressure tubing from the tubing included with the Robart Air Control Kit (not included). Connect the red tube to the front of the air cylinder and the purple to the back of the air cylinder.

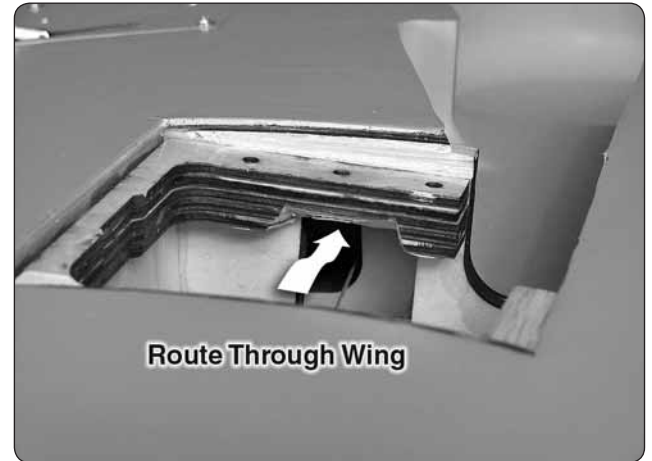

❑❑ 6. Connect both pressure tubes to the string in the retract bay. Guide the pressure tubing through the ribs and out the hole in the top of the wing. Tape the pressure tubing to the top of the wing.



□ □ 7. Secure the retracts in the wing. Apply a drop of threadlocker to the threads of six 6-32 x 3/4" [19mm] machine screws and #6 lock washers before threading them into the retract plate.

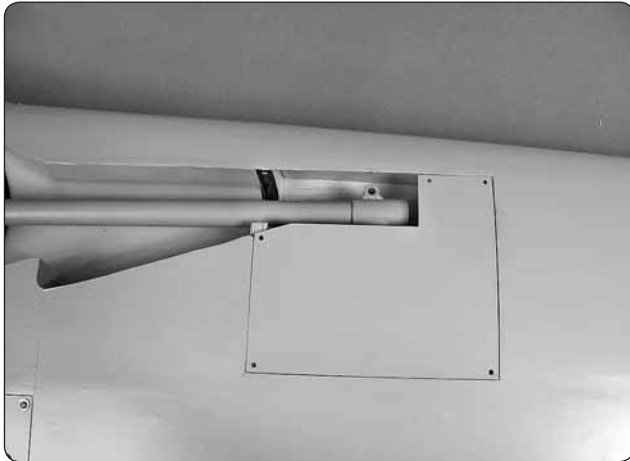

□ □ 8. Use a sharp hobby knife to remove the covering from over the five mounting holes in the plywood retract cover. Set the retract cover over the retract and drill a 1/16" [1.6mm] pilot hole using the holes in the cover as a guide.

□ □ 9. Mount the retract cover to the wing with five #2 x 3/8" sheet metal screws and five #2 flat washers. Use thin CA to harden the holes.

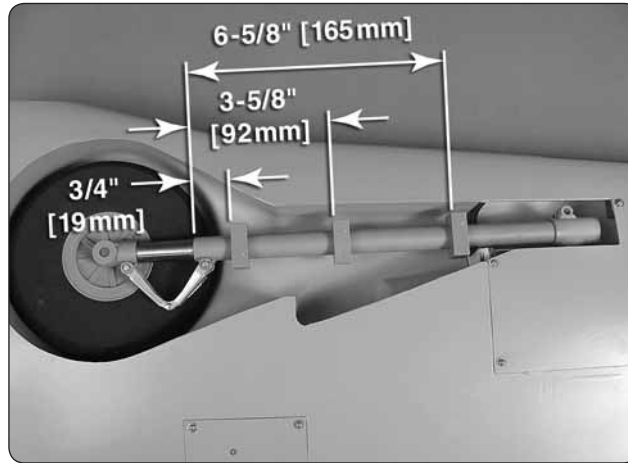

□ □ 10. Snap three of the nylon landing gear door mounts onto the landing gear strut as shown. Center the landing gear cover over the retract. Check that the landing gear door mounts are aligned with the gear door.

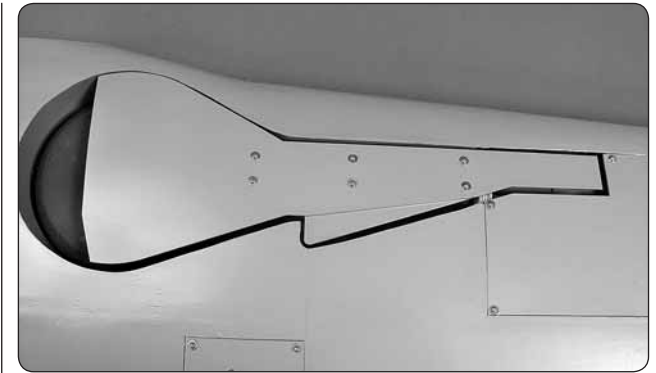

□ □ 12. Drill 1/16" [1.6mm] pilot holes at the screw locations in the cover. Secure the landing gear cover to the landing gear door mounts with six #2 x 3/8" flat-head sheet metal screws. **Note** that the landing gear cover can be rotated on the landing gear strut. Once the wing is installed on the fuselage and the orientation of the wheels is checked and correct, the landing gear door mounts can be secured to the landing gear struts with a drop of thin CA.

□ 13. Return to step 1 and mount the right retract in the right wing.

JOIN THE WING

Note: Keep the retracts in the retracted (up) position so they do not extend and retract as you handle the wing.

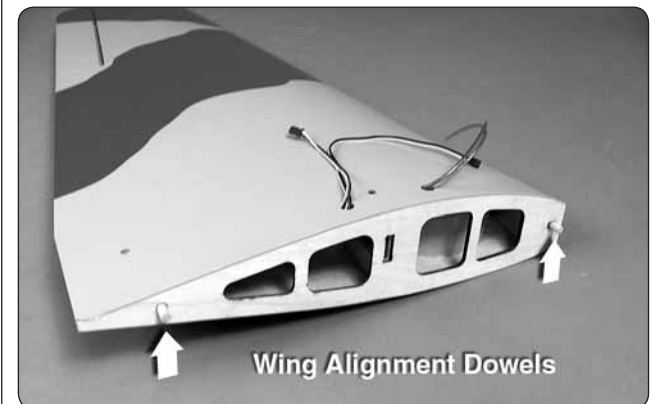

□ 1. Use 6-minute epoxy to glue the two 5/16 x 1-1/4" [8 x 30mm] wood wing alignment dowels 5/8" [15mm] into the root of the left wing half.

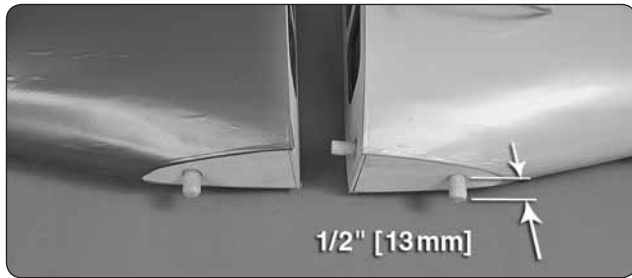

❑ 2. Use 6-minute epoxy to glue the two 3/8 x 1-3/8" [9.5 x 35mm] diameter forward wing dowels in the leading edge of the wing. The wing dowels should protrude approximately 1/2" [13mm] from the wing.

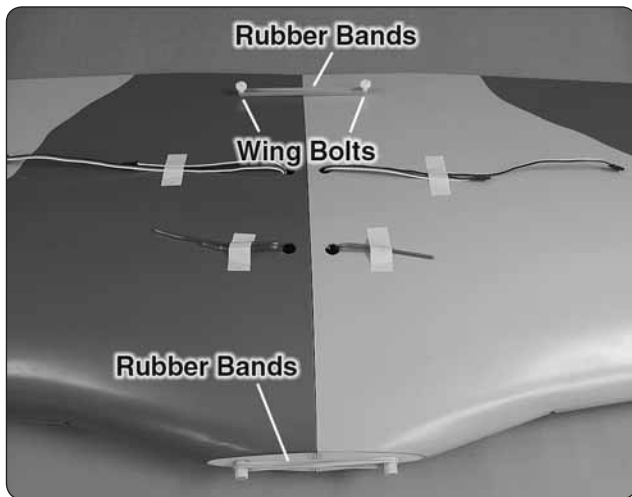

❑ 3. Test fit the hardwood wing joiner in each wing half, making sure that both wing halves fit together at the root without any gaps. Trial fit clamping the wing together with rubber bands around the wing dowels at the leading edge. Insert the two 1/4" - 20 x 2" [51mm] nylon wing bolts and stretch rubber bands around the wing bolts on the top and bottom of the wing.

❑ 4. **Read through the next three steps before mixing any epoxy.** Gather everything required for gluing the wing together including 30-minute epoxy, mixing sticks, epoxy brushes, 12" [305mm] long dowel or wire, denatured alcohol and paper towels. Remove the rubber bands and separate the wing halves. Remove the wing joiner. Mix 2 oz. [59.1cc] of 30-minute epoxy. Working quickly, pour a generous amount into the joiner pocket

of one wing half. Use your wire or dowel to thoroughly distribute the epoxy, coating all surfaces inside the joiner pocket. Coat the root rib and one half of the wing joiner that goes into the wing.

❑ 5. Coat the joiner pocket of the other wing half and the other end of the wing joiner. Join the wing halves together. Then, stand the wing on end with one of the wing tips resting on the floor. Use a piece of R/C foam or something similar to cushion and stabilize the wing so it won't slide around.

❑ 6. With the wing resting on end, use a paper towel dampened with denatured alcohol to wipe off any excess epoxy as it squeezes out. Wrap the rubber bands around the wing dowels and wing bolts. Add several strips of masking tape to tightly hold the wings together as you continue to wipe off excess epoxy as it squeezes out. Be certain the leading edge and trailing edges of the wing accurately align. Do not disturb the wing until the epoxy has fully cured.

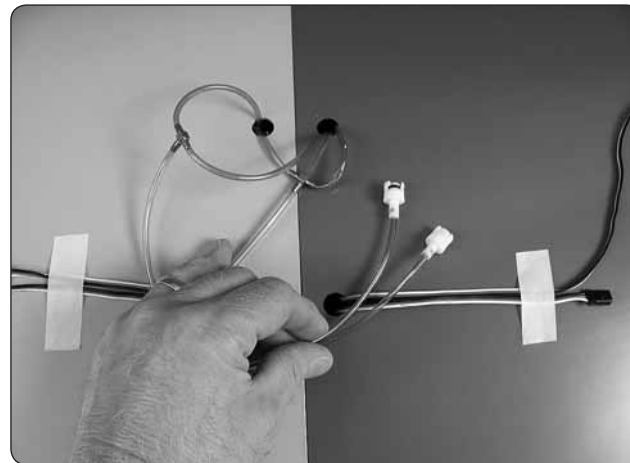

❑ 7. Join the matching air lines from each wing half with a couple of T-fittings that came with the air control kit. Cut two 10" [250mm] pieces of air line (also from the control kit) and fit each line to the T-fittings. Connect one quick-connector **with** an O-ring to one of the air lines and one of the quick connectors **without** an O-ring to the other line. This will prevent improper connection to the quick-connectors on the air valve when mounting the wing to the fuselage.

ASSEMBLE THE FUSELAGE

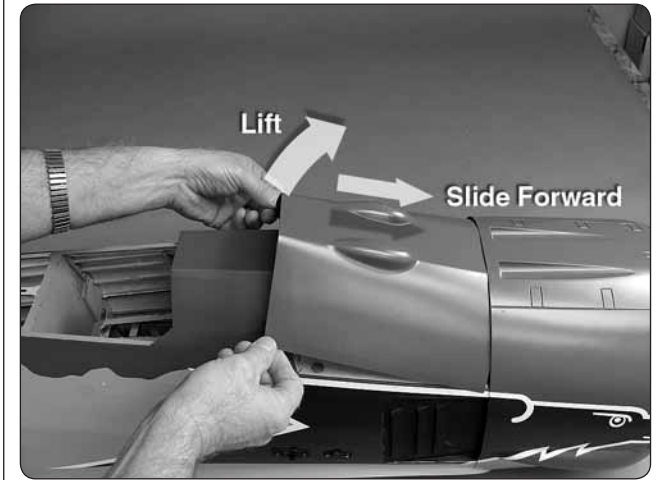

Note: To remove the forward hatch from the fuselage, slide the hatch forward, then lift.

INSTALL THE STABILIZER

Give the elevators a pull to make sure they are secure.



❑ 1. Test fit the two aluminum stabilizer tubes in the fuselage and slide the stabilizers on the tubes. The shorter tube goes in the front hole. If the aluminum tubes are too tight to slide through the holes, take a sharp hobby knife and gently scrape the inside of the holes. During the manufacturing process a small amount of resin or filler may be left behind in the hole.

❑ 2. Once you are satisfied with the fit of the stabilizer halves, remove the stabilizer halves and the joiner tubes. Use medium grit sandpaper to roughen up the aluminum tubes. Clean the tubes with denatured alcohol and insert both tubes back into the fuselage until the end exits on the opposite side by approximately 1" [25mm].

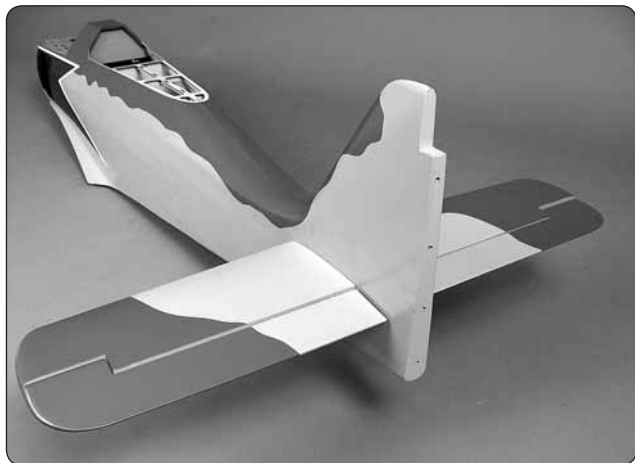

❑ 3. Gather everything required for gluing the stabilizer halves to the fuselage including 30-minute epoxy, mixing sticks, epoxy brush, 12" [304mm] long dowel or wire, masking tape, denatured alcohol and small paper towel squares. Mix up 3/4 oz. [22.1cc] of 30-minute epoxy. Apply a generous amount of epoxy to the long side of the aluminum joiner tubes. Pull the tubes through the fuselage so that they are close to centered. Pour a small amount of epoxy into both holes of one of the stabilizer halves and using a dowel or wire, coat the inside of the holes. Apply epoxy to the root rib of the stabilizer and the fuselage. Insert the end of the aluminum tubes with epoxy on them into the stabilizer and press the stabilizer against the fuselage. Wipe off any excess epoxy that may have squeezed out before it runs down the fuselage. Quickly repeat the process on the other side. Wipe off any excess epoxy with a dampened paper towel and denatured alcohol. Use pieces of masking tape to hold the stabilizer tight against the fuselage until the epoxy cures.



The Focke-Wulf Fw 190 was designed so that minimal trim changes were required at various speeds. The ailerons and rudder did not require adjustable in-flight trim tabs. Small, fixed trim tabs were attached to the trailing edge and were adjusted during the initial flight. However, the horizontal stabilizer was adjustable using an electric motor. It could be adjusted from -3 to +5 degrees of incidence.

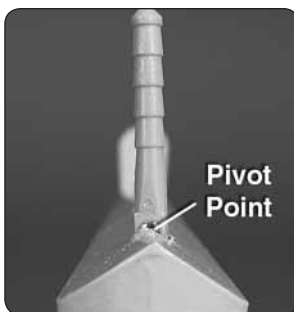

❑ 4. Without using any glue, install four hinges into the rudder. Note that the pivot point of each hinge must align with the center of the leading edge. To achieve this alignment, the hinges will be fairly deep in the rudder. Also note that the hinges must be perpendicular to the leading edge.

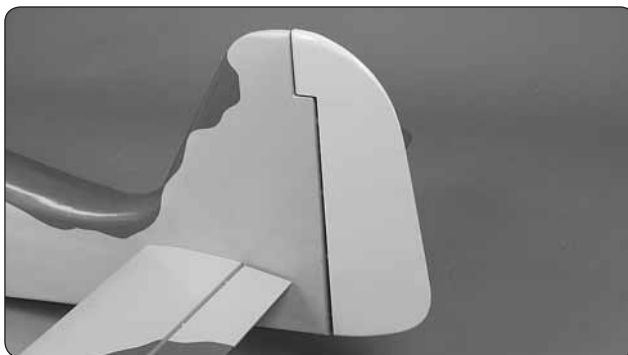
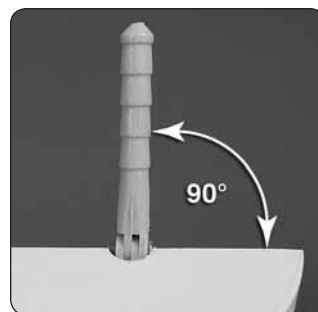

❑ 5. Again without glue, test fit the rudder to the fin. Move it left and right a few times to align the hinges. The

rudder doesn't have to move very far, only 2" [50.8mm] left and 2" [50.8mm] right measured at the widest part of the rudder at the trailing edge. If there is too much resistance, or if you are not able to move the rudder left and right 2" [50.8mm], widen the gap slightly between the rudder and fin.

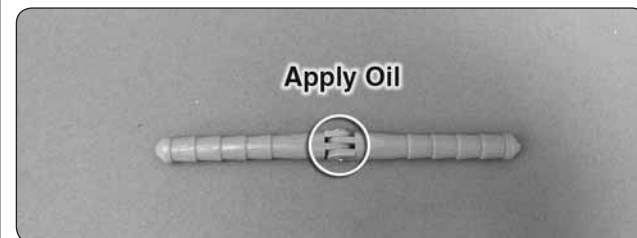

❑ 6. Remove the rudder and all the hinges. Add a small drop of oil to the pivot point on the hinges. This will prevent the epoxy from adhering to the pivot point. Make sure oil does not get on the gluing surface of the hinge. If it does, clean the oil off with a paper towel dampened with denatured alcohol.

❑ 7. Please read the complete instructions in this step before mixing up the epoxy. Mix up approximately 1/4 oz. [7.4cc] of 30-minute epoxy. Use a toothpick to thoroughly apply the epoxy in the holes in the fin and rudder. Use the toothpick to get the epoxy out of the opening of the holes in the rudder and fin so it doesn't get into the pivot pin. Wipe away any excess epoxy around the outside of the holes with a paper towel dampened with denatured alcohol.

Use the toothpick to apply epoxy to the ends of the rudder hinges that go into the fin. Insert each hinge into the fin and wipe away any excess epoxy that squeezes out of the hole.

Apply epoxy to the other end of the hinges. Join the rudder to the fin, pushing the hinges only about 3/4 of the way into the rudder. Use a toothpick to wipe away any epoxy that squeezes out. Then, fit the rudder the rest of the way on.

Move the rudder left and right a few times to align the hinges and make certain that the rudder deflects left and right enough. Allow the epoxy to cure, checking it a couple of times while it cures.

INSTALL THE ELEVATOR & RUDDER SERVOS

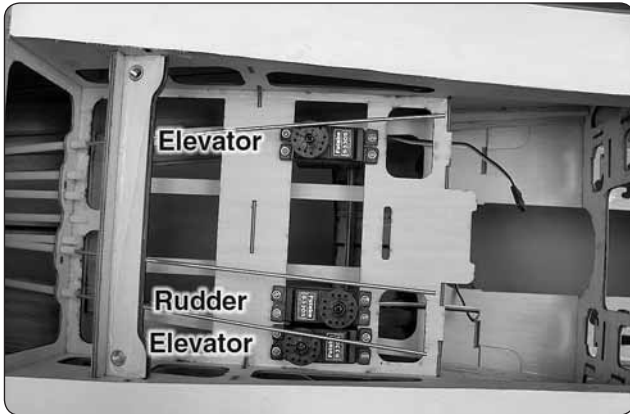

❑ 1. Insert the three 4-40 x 48" [1220mm] metal pushrods in the elevator and rudder pushrod outer pushrod tubes at the aft end of the fuselage. Install two elevator and one rudder servo in the servo tray as shown.



❑ 2. Thread a 4-40 nut, threaded clevis and a silicone clevis retainer onto both elevator pushrods and the rudder pushrod.



❑ 3. Mount the control horns to the elevators and the rudder following the same procedure used on the ailerons, by drilling 3/32" [2.4mm] pilot holes and using

#4 x 1/2" [13mm] sheet metal screws for the rudder control horn and the **front** screws in the elevator horns. **IMPORTANT:** Use #4 x 3/8" [9.5mm] sheet metal screws for the aft screws in the elevator control horn. Don't forget to harden the holes with thin CA after first installing, then removing the screws.



❑ 4. Connect the receiver battery, rudder and elevator servos to the receiver. Switch on the transmitter and center the servos. Install a single arm servo on each servo, perpendicular to the centerline of the servo. To obtain the required amount of rudder throw, a 3/4" [19mm] servo arm was installed on the rudder servo.

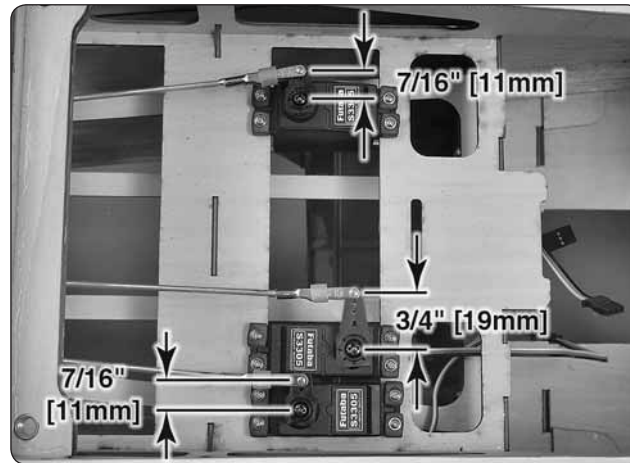

❑ 5. Install solder clevises on the elevator servo arms in the hole 7/16" [11mm] from the center of the servo arm.

Install a solder clevis on the rudder servo arm in the hole 3/4" [19mm] from the center of the servo arm. Follow the same procedure that was used for the aileron and flap pushrods. Mark the elevator and rudder pushrods where they are to be cut for the solder clevises. One at a time, remove the threaded metal clevis from the control horn end, remove the pushrod from the fuselage, cut it to the correct length and solder a metal solder clevis on the end. Reinstall the pushrod inside the fuselage and connect the solder clevis to the servo arms. Reinstall the threaded metal clevis and 4-40 nut. **Don't forget to use a silicone clevis retainer on all the clevises.**

MOUNT THE RETRACTABLE TAIL GEAR



❑ 1. Remove the steering arm from the Robart #160 retractable tail gear assembly (not included). File a flat spot near the top of the shaft for the set screw in the steering arm to lock onto. File a second flat spot near the bottom of the shaft for the set screw in the strut. Mount the strut on the shaft with a drop of threadlocker on the set screw.

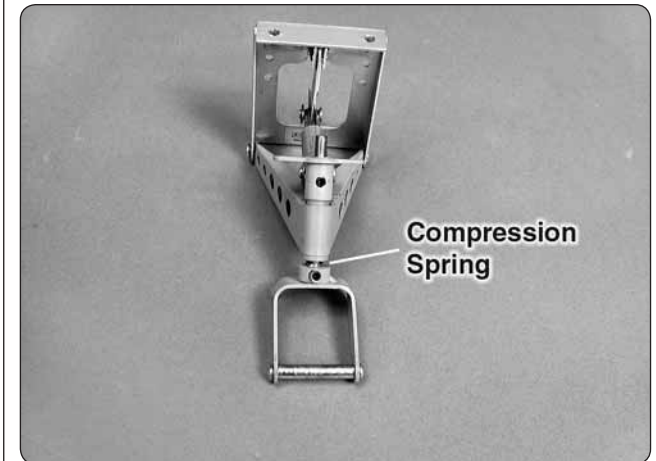

❑ 2. Install the compression spring, included with the Fw 190, on the shaft, between the strut and the tail gear frame. Compress the spring while tightening the set screw in the steering arm.



❑ 3. Enlarge the hole through the 1-3/4" [44mm] tail wheel with a #11 [4.8mm] or 13/64" [5mm] drill. Install a 13/64" [5mm] thick spacer (included with the Fw190) on each side of the tail wheel. Install the tail wheel in the strut. Be sure to apply a drop of threadlocker to the two mounting screws.

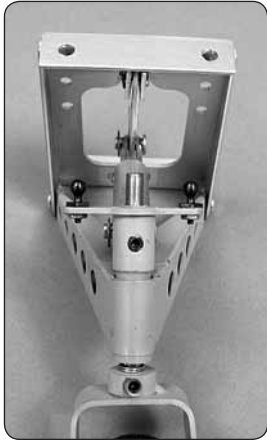

❑ 4. Insert an .080 ball link ball in both holes of the steering arm. Secure each ball with a .080 nut and a drop of threadlocker.

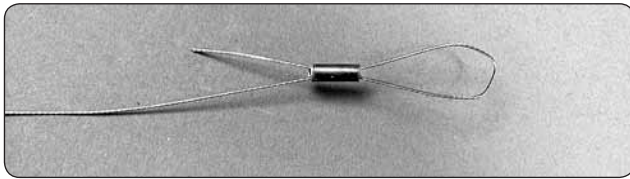

❑ 5. Slide a small copper tube (called a swage) over one end of the .020 x 80" [.5 x 200cm] braided cables, then guide the end of the cable back through.

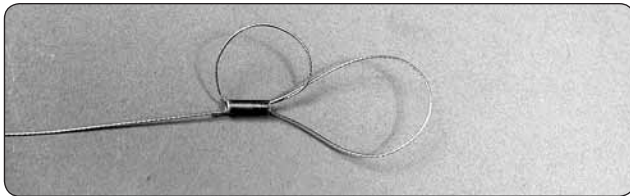

❑ 6. Wrap the cable back around the swage and back through the swage.

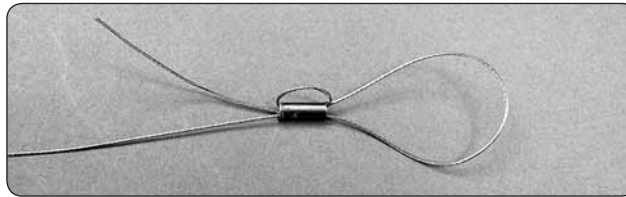

❑ 7. Use pliers to pull the cable from the first loop to reduce the size of the second loop.

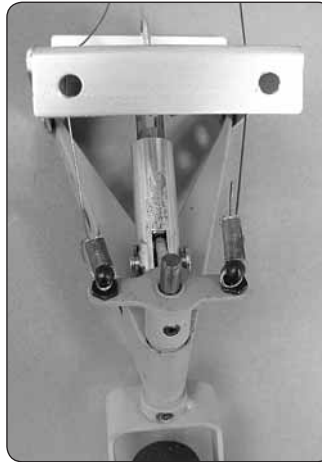

❑ 9. Place the tail gear in the fuselage while simultaneously guiding the pull/pull cable through the white plastic guide tubes.

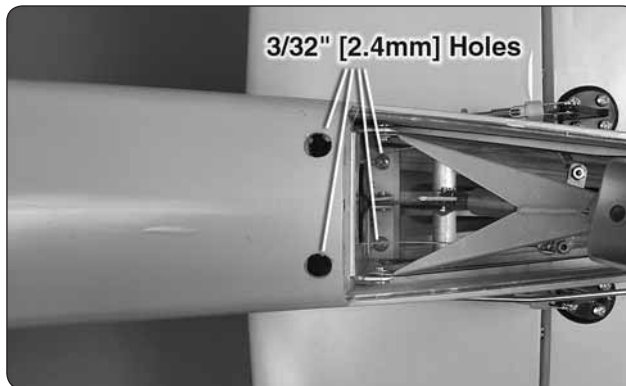

❑ 10. Drill four 3/32" [2.4mm] holes through the rails for mounting the tail gear.



If your drill bit is not long enough to reach the rail nearest the top of the fuselage, use medium CA to temporarily glue a 3/32" [2.4mm] drill bit in a 1/8" [3.2mm] brass tube. After drilling the holes, the drill can be removed from the tube by heating the tube.

❑ 11. Mount the tail gear in the fuselage with four #6 x 1/2" [13mm] sheet metal screws. Harden the screw holes with CA.



❑ 12. Install the tail wheel steering servo in the center of the servo tray. Remember to harden the screw holes with thin CA.

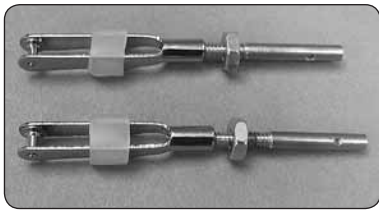

❑ 13. Thread a 4-40 nut and a 4-40 metal clevis on to each of the 4-40 rigging couplers. Slide a silicone clevis retainer over each clevis. Install the clevises on the steering servo arm in the hole 3/8" [9.5mm] from the center of the servo arm.



❑ 14. Center the servo arm and the tail gear. Install a swage on each cable, securing it following the same procedure used on the tail gear. Use a pliers to crimp the swage tightly on the cable.



❑ 15. Insert a 4-40 x 48" metal pushrod in the tail gear retract outer pushrod tube.

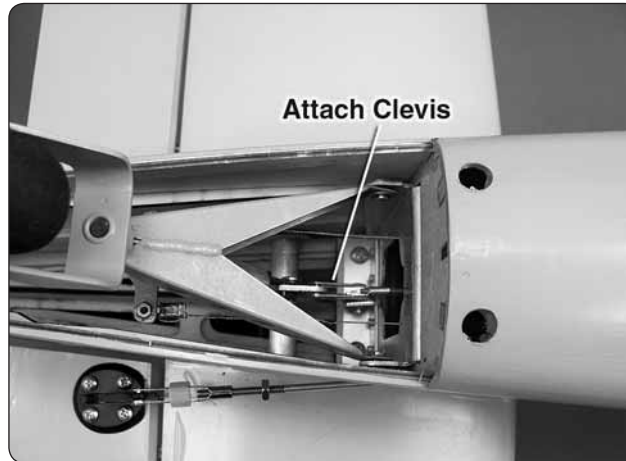

Attach Clevis

❑ 16. Thread a 4-40 metal clevis 14 turns onto the threaded end. Attach the clevis to the tail gear retract arm.

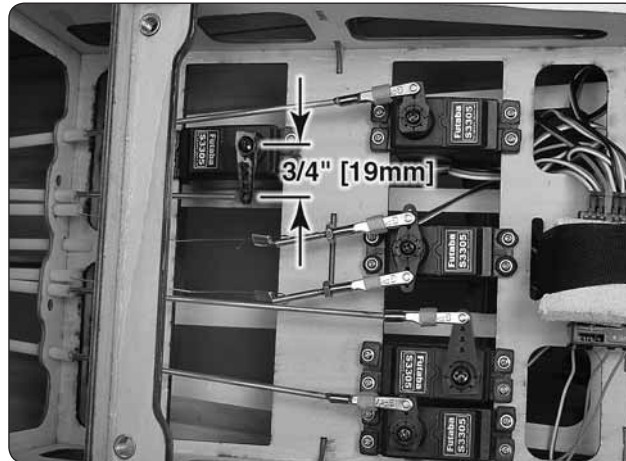

3/4" [19mm]

❑ 17. Install a 3/4" [19mm] servo arm on the tail gear retract servo. Install the servo in the aft servo tray so that the hole 3/4" [19mm] from the center of the servo arm is aligned with the tail gear retract pushrod.

❑ 18. Connect the servo to the receiver. Position the servo horn on the servo so that it moves approximately the same distance both directions.



❑ 19. Position the retract switch so that the gear is in the down position and lock the tail gear in the down position. Install a 4-40 solder clevis on the servo arm. Following the same procedure as before, mark and cut the pushrod to length.



❑ 20. Remove the pushrod from the fuselage and remove the 4-40 threaded metal clevis. Reinsert the non-threaded end of the pushrod into the outer pushrod tube from the servo end. Pull the pushrod out from the retract opening enough to solder the 4-40 solder clevis on the pushrod. Do not pull the pushrod all the way out. It will be very difficult to insert the pushrod from the aft end.

❑ 21. Slide a silicone clevis retainer over the solder clevis. Connect the solder clevis to the tail gear retract.

❑ 22. Thread a 4-40 nut and then the 4-40 metal clevis, with the silicone clevis retainer, on the threaded end of the tail gear retract pushrod. Connect the clevis to the

servo arm and check the operation. Apply a drop of threadlocker to the pushrod and tighten the nut against the clevis.

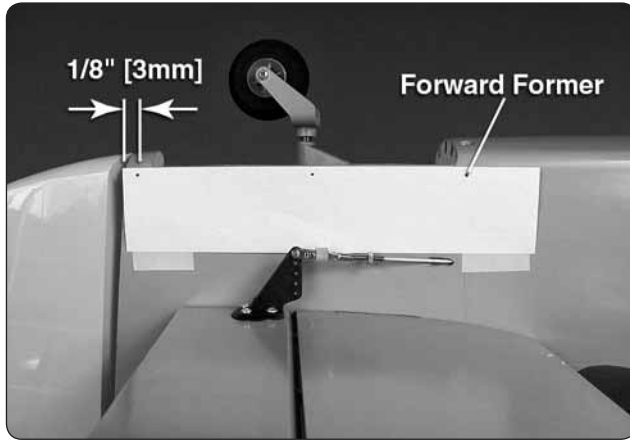

❑ 23. The tail gear retract cover can be permanently installed using CA glue or with screws. If CA glue is used it will be difficult to remove the cover and access the retract if needed. To install the cover with screws, tape a piece of paper to the fuselage, flush with the edge of the tail gear opening. Place marks 1/8" [3mm] from the edge at the aft end, in line with the forward former and in the center of the opening.

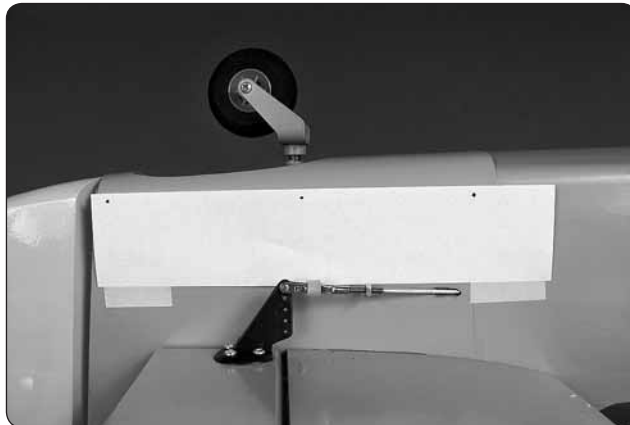

❑ 24. Center the tail gear retract cover over the opening and flush with the aft end of the fuselage. Tape it in place. Drill 1/16" [1.6mm] pilot holes through the cover and the fuselage at each mark.



❑ 25. Remove the cover and enlarge only the holes in the cover with a 3/32" [2.4mm] drill bit. Attach the cover to the fuselage with #2 x 3/8" [9.5mm] sheet metal screws and #2 washers. Harden the screw holes with thin CA glue.

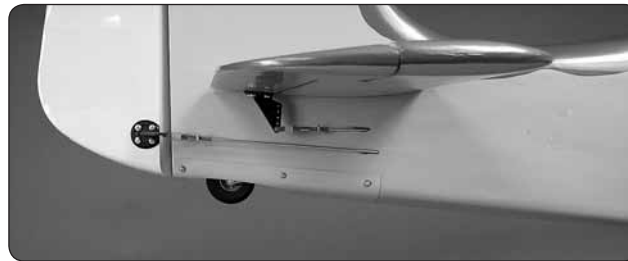

❑ 26. On the full scale FW 190A-3 the tail wheel did not retract fully into the fuselage. The amount of throw can be adjusted by the position of the servo arm on the servo or reducing the throw electronically on the transmitter.



Fw 190 FACT

The Fw 190A-3 used the air-cooled BMW 801 D-2 engine which produced 1,677 hp. It had a ceiling of 34,775 ft (10,599 m), a range of 497 miles (800 km) and a top speed of 418 mph (673 km/h). To help cool the engine a 12 bladed cooling fan was mounted behind the propeller, just inside the front of the cowl.

INSTALL THE ENGINE

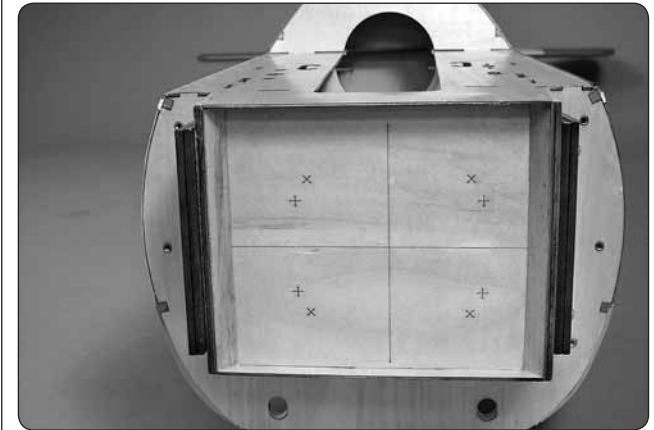

❑ 1. The firewall has two sets of engine mounting bolt patterns embossed on it. The "+" are for the Fuji™ BT-43EI-2 gas engine and the "X" are for the DA-50, DLE-55 and O.S.® GT55 gas engines. If you are installing an engine with a different mounting bolt pattern the firewall also has crosshairs embossed on it to help locate the correct mounting location.

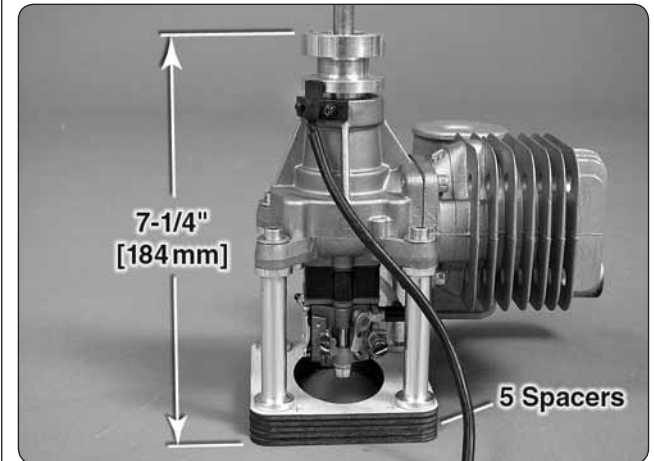

❑ 2. Drill a 13/64" [5mm] hole through the firewall at each of the appropriate locations marked with an "X" or "+". Also glue together the required number of motor spacers and drill 13/64" [5mm] holes through them. For reference, the distance from the front of the firewall to the front of the drive washer is 7-1/4" [184mm]. The DLE-55 engine requires five of the plywood engine spacers.

❑ 3. Insert four 10-32 x 1-1/2" [38mm] socket head cap screws, #10 lock washers and #10 Fender washers (not included) through the holes from the backside of the firewall. Slide the plywood engine spacers over the screws. Apply a drop of threadlocker to the threads of each screw. Thread the engine standoffs onto the screws and tighten them against the plywood engine spacers.

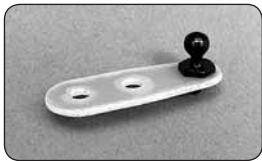

❑ 4. If installing the DLE-55 engine, install a 2-56 ball link ball on the throttle arm extension and secure it with a 2-56 nylon nut.



❑ 5. Remove the throttle arm from the carburetor. Using the screw and nut supplied with the throttle arm extension, attach the extension to the throttle arm. Again, use threadlocker on the threads.

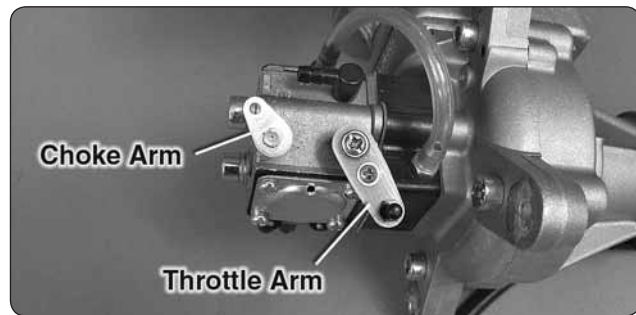

❑ 6. Reinstall the throttle arm on the carburetor so that it is opposite the choke arm.

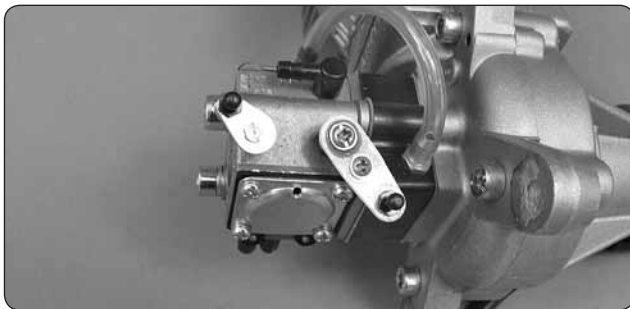

❑ 7. Install a 2-56 ball link ball on the choke arm and secure it with a 2-56 nylon nut.

❑ 8. Temporarily install the engine inverted on the aluminum standoffs. Determine on which side of the fuselage the throttle and choke servos need to be installed.

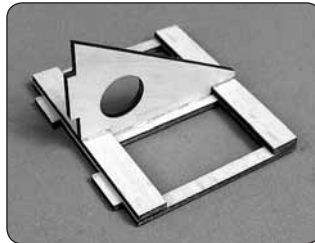

❑ 9. Glue the two plywood servo tray doublers to one side of the throttle/choke servo tray. Then, glue the vertical servo tray support over the doublers.

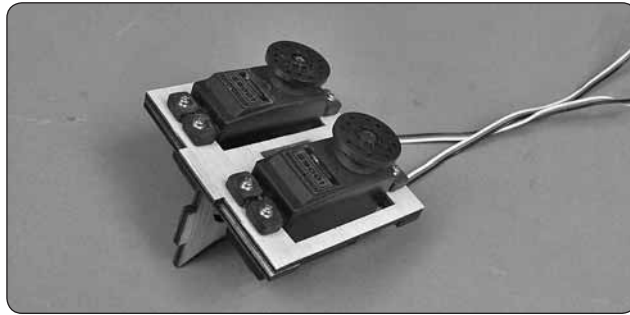

❑ 10. Install the throttle and choke servos in the servo tray. Remove the screws and servos and harden the screw holes with thin CA. Do not reinstall the servos until the servo tray has been installed in the fuselage.

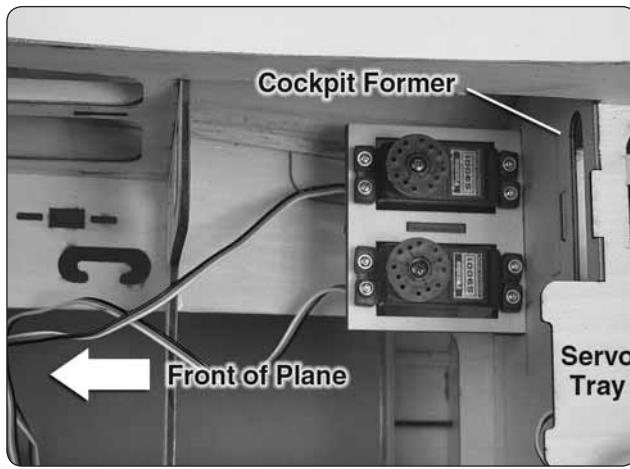

❑ 11. Glue the throttle/choke servo tray to the front of the cockpit former.

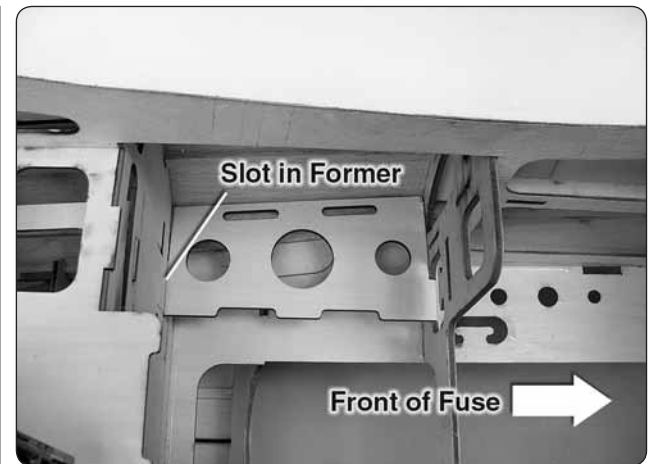

❑ 12. On the opposite side of the fuselage, glue the receiver battery tray to the front of the cockpit former and the aft fuel tank former.

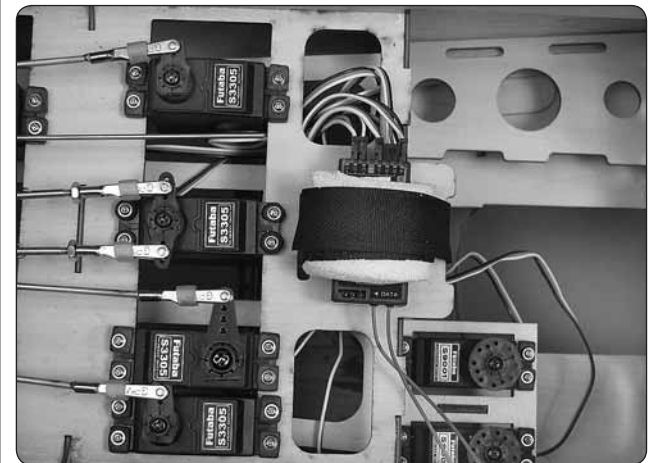

❑ 13. Plug the throttle and choke servos into the receiver. Wrap the receiver in foam and secure it to the servo tray with hook and loop material. To make the strap, overlap by 1" [25mm] the hook material with the loop material.

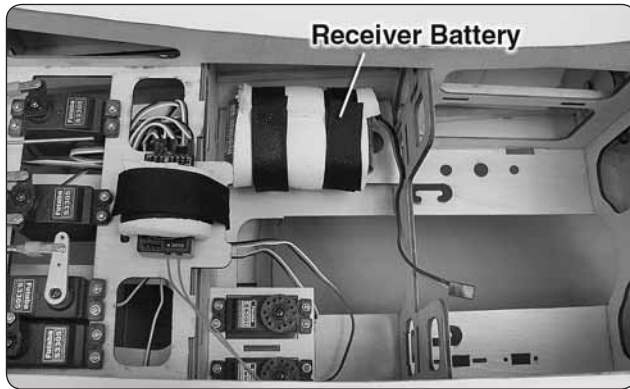

- ❑ 14. Wrap the receiver battery in foam and use hook and loop material to secure it to the receiver battery tray.

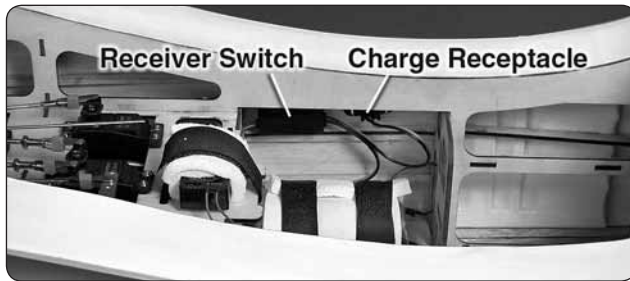

- ❑ 15. Install the receiver switch and charge receptacle. We installed ours just below the receiver battery.



- ❑ 16. Drill a 3/16" [4.8mm] hole inline with the throttle and choke ball link balls. You may find it easier to remove the engine before drilling the holes. Cut two 8-1/2" [216mm] long outer pushrod tubes from the

20" [500mm] long outer pushrod tube. Use medium sandpaper to roughen the outer pushrod tubes. Clean the tubes with denatured alcohol and insert the tubes into the previously drilled holes in the firewall. Route the tube through the slot in the former until it is flush with the front of the firewall. Use thin CA to glue the tube to the firewall.

- ❑ 17. Reinstall the engine on the standoffs using the bolts and washers supplied with the engine. Apply a drop of threadlocker to each bolt before installing.



- ❑ 18. To make a throttle pushrod, thread a 2-56 x 1" [25mm] threaded rod approximately 3/8" [9mm] into the end of the white inner pushrod tube. Thread a nylon ball link socket onto the threaded rod. For the DLE engine, trim the inner pushrod tube 10" [254mm] long.

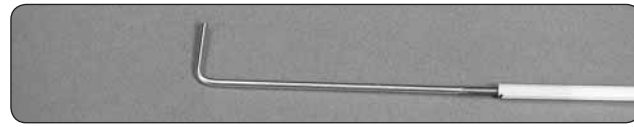

- ❑ 19. Make a 1/2" [12mm] long L-bend at the non-threaded end of the 2-56 x 4" [102mm] metal pushrod. Thread the other end 3/4" [19mm] into the end of the throttle pushrod tube. The L-bend makes it easier to thread in.



- ❑ 20. Cut off the L-bend from the 2-56 x 4" [102mm] pushrod. Insert the throttle pushrod into the throttle outer pushrod tube. Attach the ball link socket to the ball link ball on the throttle arm.

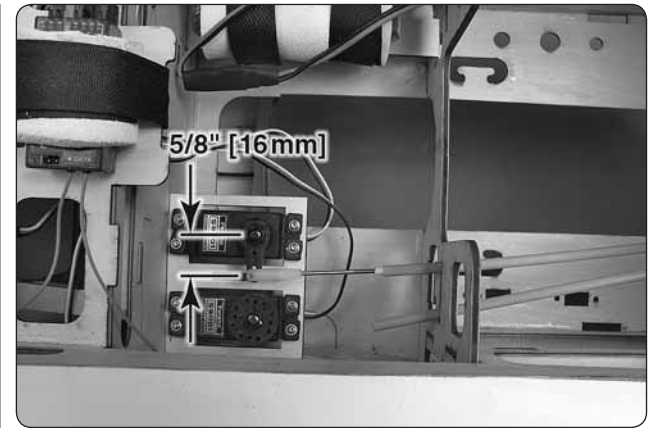

- ❑ 21. Position the throttle stick so that it is centered on the transmitter. Adjust the throttle servo arm so that it is centered on the throttle servo. Move the throttle arm on the carburetor so that the throttle is open approximately half way. Mark the throttle pushrod where it crosses the servo arm 5/8" [16mm] from the center of the servo. Make a 90 degree bend at the mark and secure the throttle pushrod to the servo arm with a nylon Faslink.

- ❑ 22. Now it should only require minor adjustments to the throttle endpoints on the transmitter so that the throttle opens and closes completely. Be sure to also set up a throttle cut switch on your transmitter to close the throttle completely, stopping the engine.

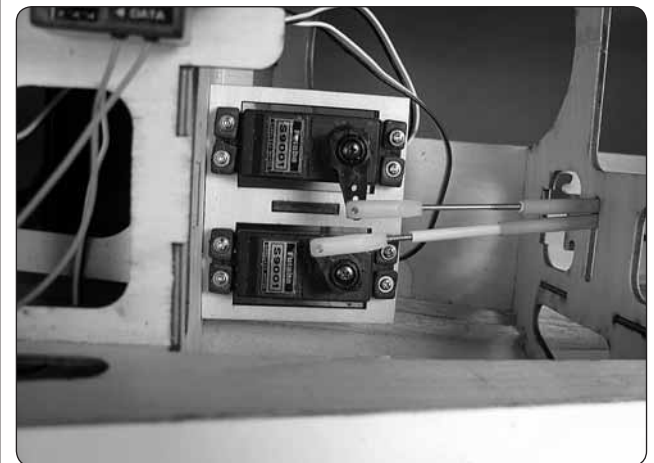

- ❑ 23. Install the optional, servo operated choke following the same procedure.



❑ 24. Glue the throttle and choke outer pushrod tubes to the former.

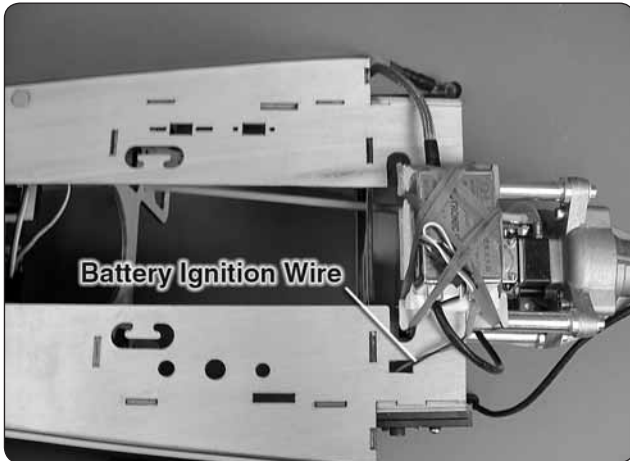

❑ 25. Place the ignition module on a piece of R/C foam rubber and secure it to the top of the air tank tray with four rubber bands. Route the battery wire for the ignition module through the hole in the tray.

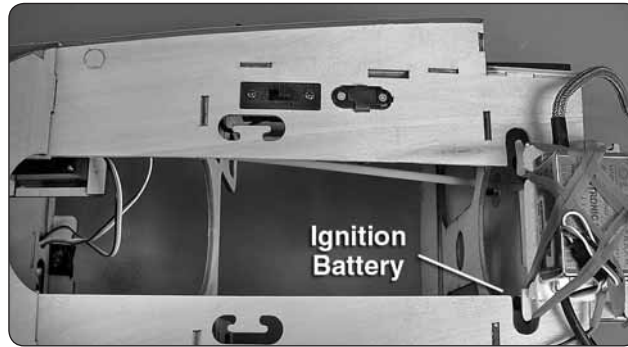

❑ 26. Install the on/off switch and the charge jack in the air tank tray.

❑ 27. Wrap the ignition battery in R/C foam rubber and connect it to the ignition on/off switch. We positioned our ignition battery behind the firewall, using a couple of sticks to hold it securely. Depending on the size of your ignition battery, the location may vary.

ASSEMBLE AND INSTALL THE FUEL TANK

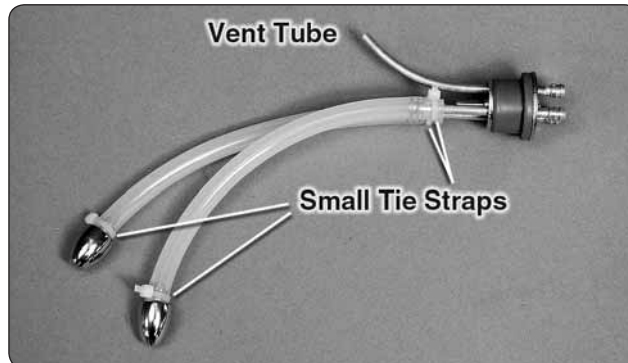

❑ 1. Assemble the fuel tank stopper assembly with the Tygon fuel tubes (not included) as shown. The easiest way is to first solder a fuel line barb (not included) onto

one end of all three tubes. Insert the tubes into the stopper with the metal plates, and then solder a barb onto the other end of the two short tubes. Bend the vent tube and connect the pickup and fueling/defueling lines (not included) to the short tubes. Connect the clunks to the lines and secure the lines to the clunk and brass tubing with the small tie straps.

❑ 2. Install the fuel tank stopper assembly in the fuel tank. Check that the clunks move around freely in the fuel tank. Tighten the fuel tank stopper screw. Mark the top of the fuel tank (the side the vent tube is on).

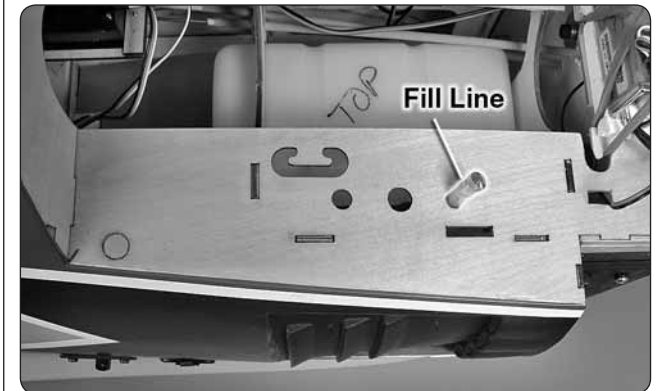

❑ 3. Position the fuel tank in the fuselage and determine how you want to run the fuel line. Drill holes where necessary in the firewall for the line going to the carburetor and the vent line. The third fill line can be routed up through the air tank tray. Install an aluminum fuel line plug in the fill line. Secure the fuel tank in the fuselage with the rubber bands.

INSTALL THE AIR RETRACT CONTROLS

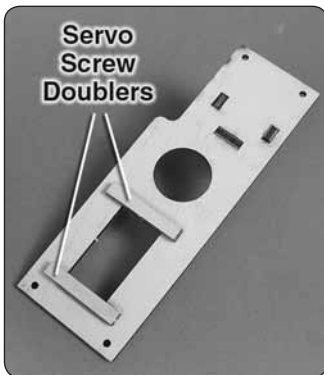
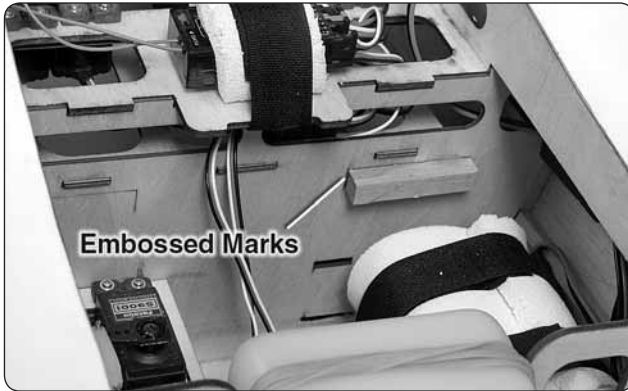

- ❑ 2. Glue the retract servo tray together as shown.

❑ 1. Use epoxy to glue the two 5/16" x 1-3/4" [8mm x 44mm] hardwood rails to the fuel tank former and servo tray former. Use the embossed marks on the servo tray former to locate the aft hardwood rail. The forward hardwood rail should be aligned with the bottom of the opening in the fuel tank former.

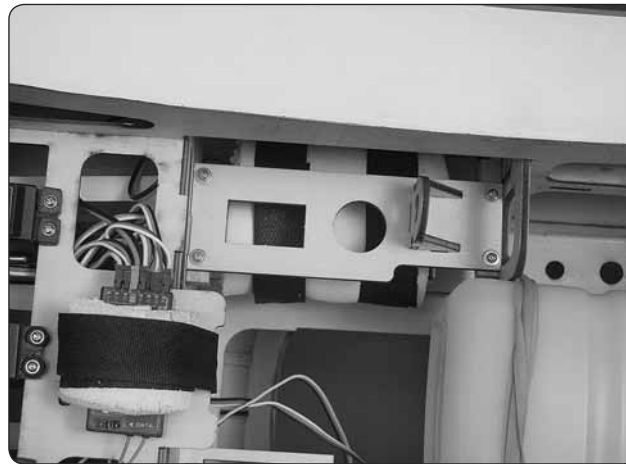

❑ 3. Test fit the retract servo tray in the fuselage. It should fit between the two hardwood rails. Drill a 1/16" [1.6mm] pilot hole in the hardwood rails using the four mounting holes as guides. Attach the retract servo tray to the rails with #2 x 3/8" [9.5mm] sheet metal screws and #2 washers. Remove the screws and the tray and harden the screw holes with thin CA.

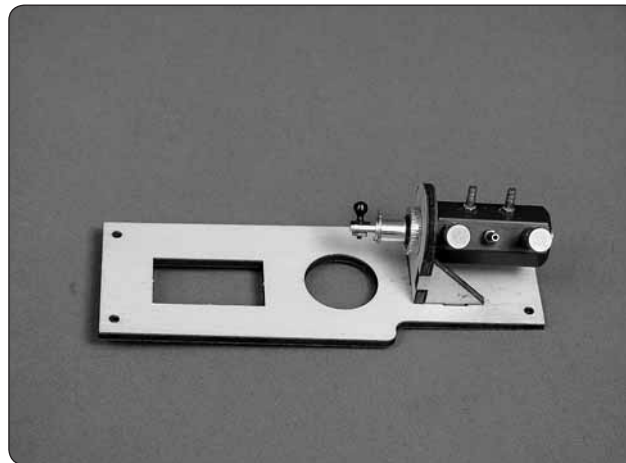

❑ 4. Install the retract control valve in the plywood mount. Install a .080 ball link ball and .080 nut on the valve. Be sure to use a drop of threadlocker on the threads of the ball link ball.

❑ 5. Install the retract control valve servo in the retract servo tray and plug into the receiver.

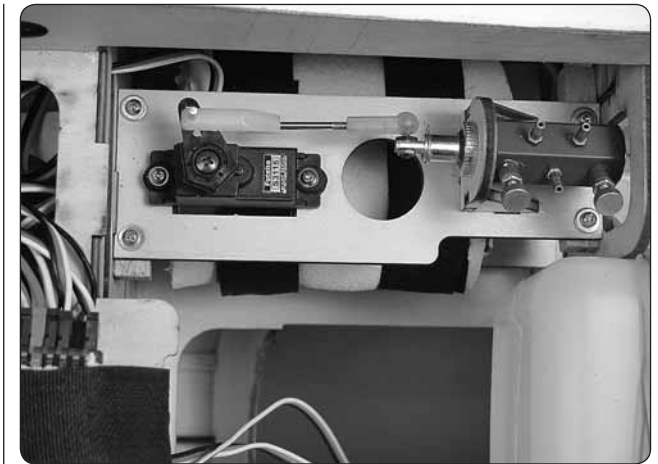

❑ 6. Cut off 1/2" [13mm] from the threaded end of the 2-56 x 4" [102mm] metal pushrod. Thread the nylon ball socket on the pushrod. Snap the ball socket onto the ball link ball on the retract control valve. Center the servo arm and mark the pushrod where it crosses the servo arm. Make a 90 degree bend at the mark. Install the pushrod in the servo arm and install a nylon Faslink. Cut the pushrod 1/8" [3mm] past the Faslink. Reinstall the retract servo tray in the fuselage with the #2 x 3/8" [9.5mm] sheet metal screws and #2 washers.



❑ 7. Install a length of air line on the pressure tank. Secure the pressure tank in the cradle with a rubber band. To prevent the tank from sliding, a couple of dabs of silicone adhesive can be applied to the cradle.

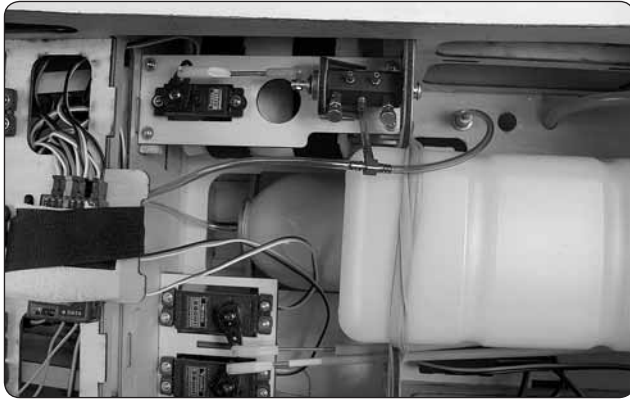

the other end of the two air lines. Important: Check the wing as to which quick connect to install on which color air line.

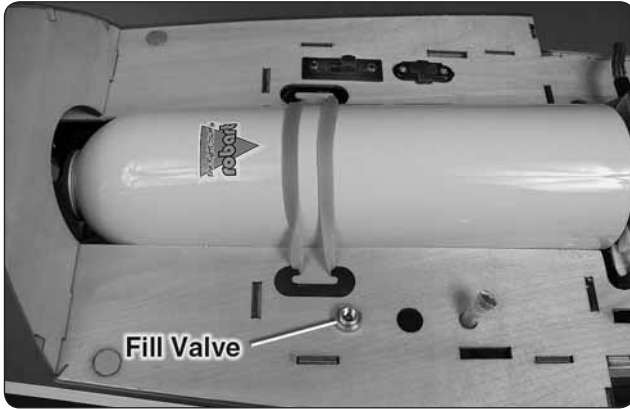

❑ 10. A method used to mount servo wires and air line tubing to a structure is to cut a strip of rubber band. Position the rubber band over the wires and glue the ends of it to the structure.



Fw 190 FACT

The Fw 190A-3 came with two 7.92mm MG 17 machine guns in the cowl, two 20mm MG 151/20E cannons in the root of the wing and two 20mm MG FF cannons in the outer wing panels.

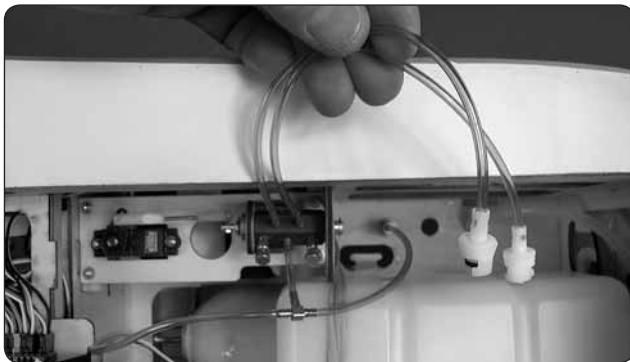

❑ 9. Connect an 8" [203mm] long red and purple air line to the air control valve. Install quick connects on

INSTALL THE COWL

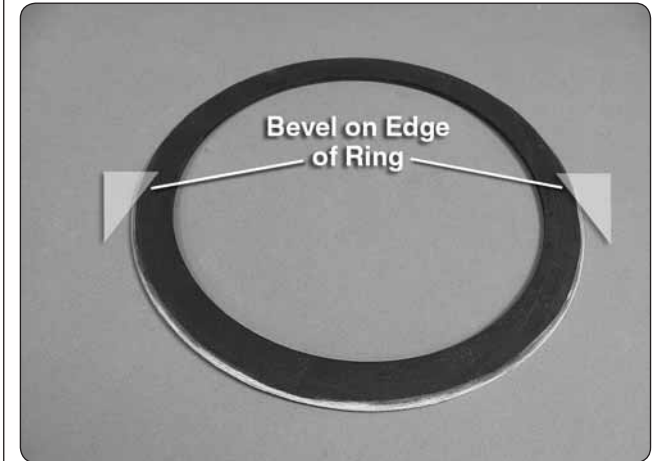

❑ 1. Using a sanding bar or block with coarse sand paper, sand a bevel around the edge of the plywood fan ring. When properly sanded the ring should hold the plastic fan tight against the front of the cowl.



❑ 2. Use sand paper to roughen the back of the outer ring of the plastic fan. Clean the sanded area with a paper towel dampened with denatured alcohol.



❑ 3. Center the plastic fan in the cowl opening. Apply a couple drops of thin CA to the joint between the fan and the cowl to hold it in place.

❑ 4. Lightly sand the inside of the cowl around the edge of the plastic fan. Clean the area with a paper towel dampened with denatured alcohol.

❑ 5. Apply a bead of epoxy to the back of the outer ring of the fan and the front and edge of the plywood fan ring. Position the plywood ring on top of the plastic fan. Place weight on the ring to hold it in position until the epoxy cures.



❑ 6. Use epoxy to make a fillet between the cowl and the edge of the plywood fan ring. For a stronger fillet milled fiberglass can be mixed with the epoxy.

See page 35 for instructions on how to make a long 7/64" Hex-ball Wrench.

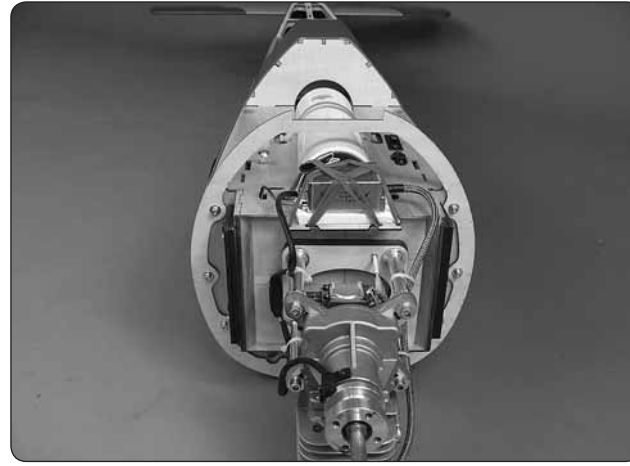

❑ 7. Attach the plywood cowl ring to the front of the fuselage with six 6-32 x 5/8" socket head cap screws, #6 lock washers and #6 flat washers.

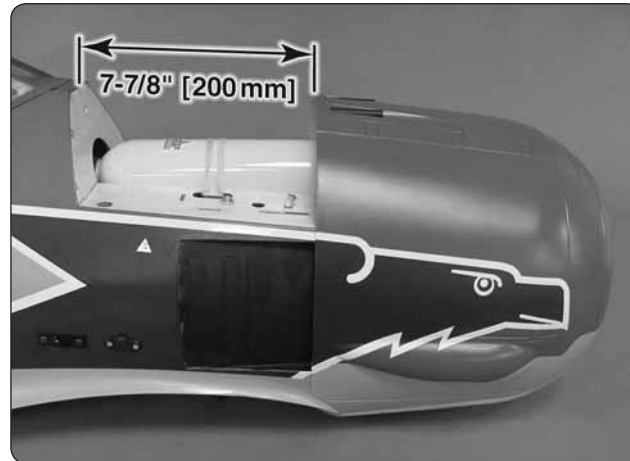

❑ 8. Test fit the cowl over the engine. The bottom of the cowl will need to be trimmed to fit over the engine head. For right now just get the cowl centered around the engine drive washer and the cowl in the correct position 7-7/8" [200mm] from the back of the air tank tray.

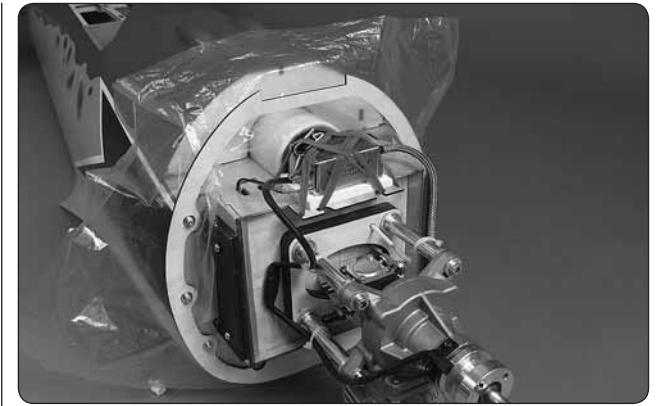

❑ 9. Remove the cowl and the cowl ring. Cut a hole in the center of the plastic bag the cowl came in and slide the plastic bag over the front of the fuselage so that it covers the firewall. Reinstall the cowl ring. The bag is to prevent glue from getting on the fuselage when the cowl is glued to the cowl ring.

❑ 10. Sand the inside of the cowl where the cowl ring contacts the cowl. Then, clean it with a paper towel dampened with denatured alcohol.

❑ 11. Mix up 1/2 oz. [4 drams] of 30-minute epoxy. Apply the epoxy to the inside of the cowl where it contacts the cowl ring. Slide the cowl over the cowl ring, centering it over the drive washer on the engine and aligning it correctly on the fuselage. Use masking tape to hold it in position until the epoxy cures.

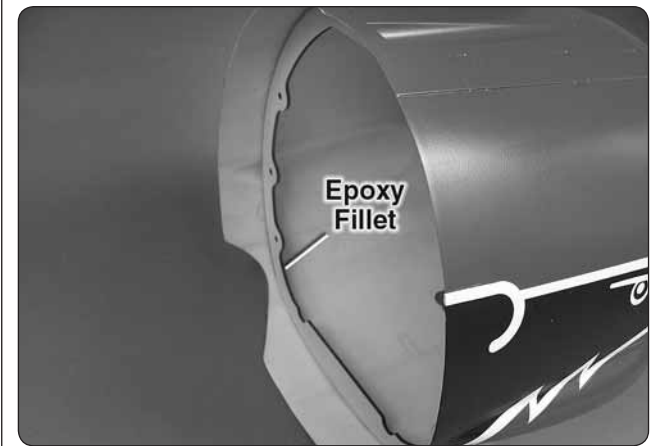

❑ 12. Remove the cowl using the included long hex wrench. Use epoxy to make a fillet between the cowl and

the front edge of the plywood cowl ring. For a stronger fillet milled fiberglass can be mixed with the epoxy.

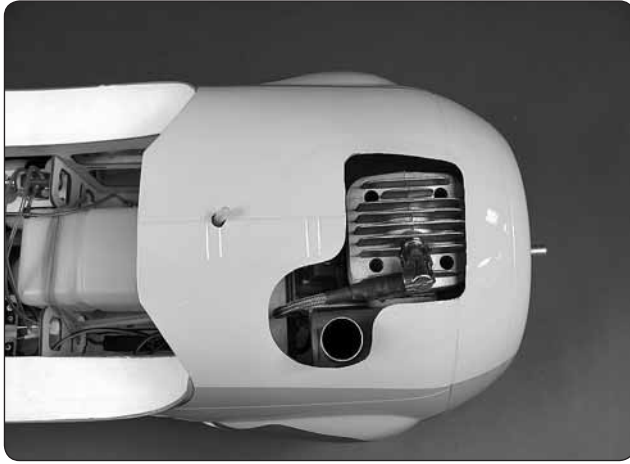

❑ 13. Position the cowl back on the fuselage. Mark and trim the cowl from around the cylinder head and muffler. The stock muffler included with the DLE-55 engine fits great inside the cowl. A Pitts style muffler can also be used.

APPLY THE FINAL DETAILS

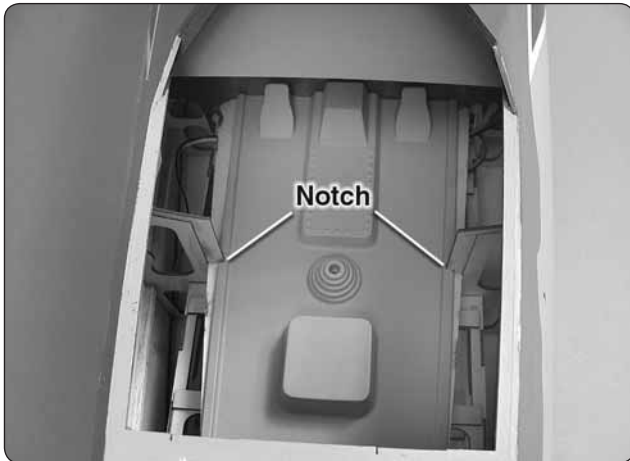

❑ 1. Trim the cockpit floor along the edge so that it lays flat. Use medium CA to glue the floor in the bottom of the cockpit. The edge of the floor will need a notch cut in it to fit around the former.

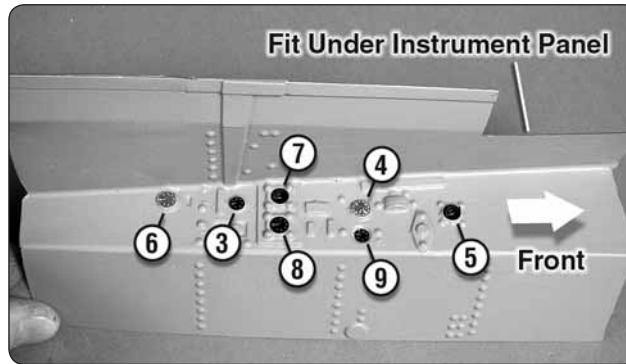
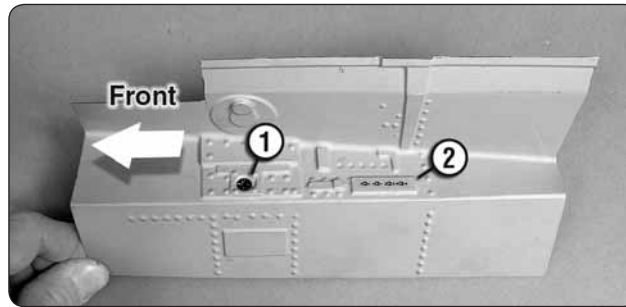

❑ 2. Trim the two side panels. Note that the front of each panel will need to be trimmed to fit past the instrument panel. Install the decals on the side panels as shown. See the decal key on page 34.



❑ 3. Once satisfied with the fit of the side panels in the fuselage, glue them in position. We found that using canopy glue along the bottom and aft end of the panels worked well. Then, use CA along the top edge to glue the side panels under the lip.

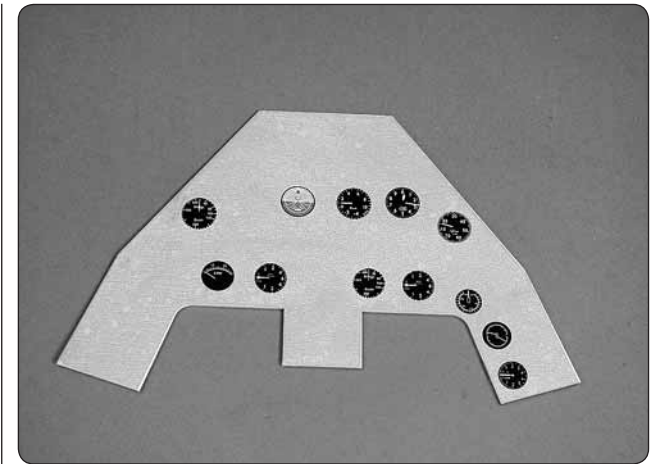

❑ 4. Apply the instrument panel decals to the plywood instrument panel backplate. Position the backplate behind the instrument panel. Adjust the backplate, sanding the edges, so that the instrument dials line up with the openings.

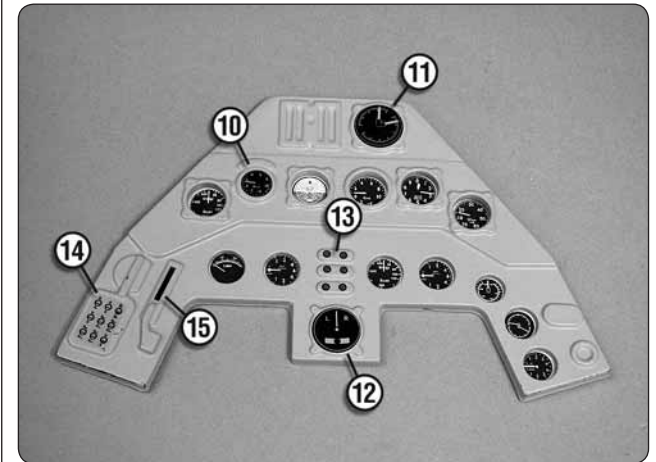

❑ 5. Glue the instrument panel backplate to the back of the instrument panel. Apply the remaining instrument decals to the front of the instrument panel as shown. See the decal key on page 34.

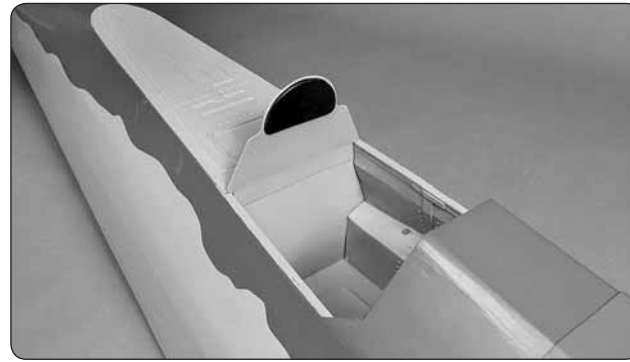

❑ 8. Center and glue the armor plate to the back of the cockpit.



❑ 6. To install the instrument panel, first, insert the bottom of the panel face down. Apply glue to the back of the panel, then rotate the panel into position.

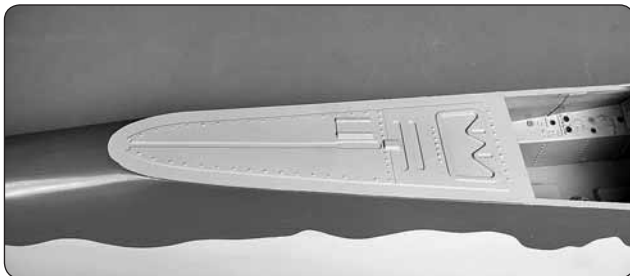

❑ 7. Trim the edges of the canopy deck so that it fits flush with the sides of the fuselage. Glue the canopy deck to the fuselage.

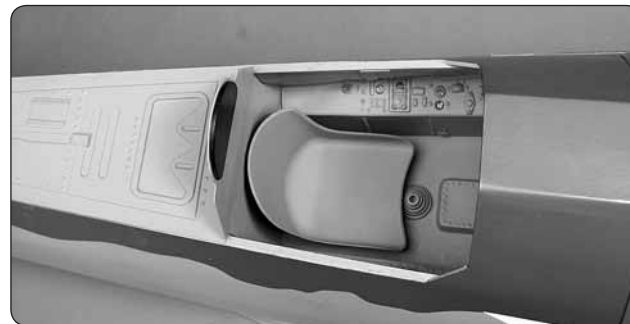

❑ 9. Sand the bottom center of the seat and the top of the seat pedestal. Clean the area with denatured alcohol and glue the seat to the pedestal.

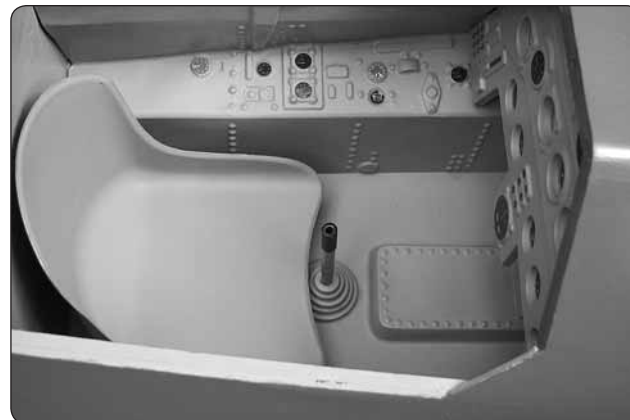

❑ 10. If you are installing a full body pilot, now is a good time to install him before the control stick is installed. Cut the control stick to the appropriate length using the

height of the seat as a guide. Glue the control stick in the control stick boot.



❑ 11. Apply the "Attention" decal to the armor plate.



❑ 12. Install the pilot bust in the cockpit. You will need to use a block to raise the pilot.

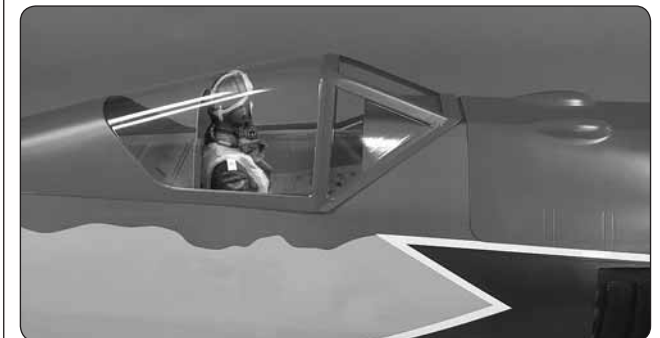

❑ 13. Wash the canopy in warm water. Then, dry it off. Place the canopy on the fuselage. Be certain it is centered from side-to-side and mark the outline on the

fuselage. Use a T-pin to prick holes in the covering or trim and remove the covering, just inside the outline. Use canopy glue to attach the canopy on the fuselage.

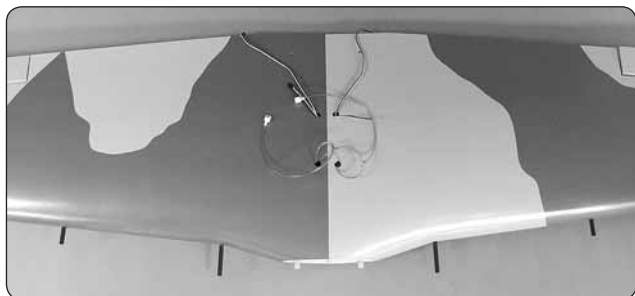

❑ 14. Insert the guns in the wing and mark the joint between the wing and gun. Remove the guns and use sandpaper to remove the paint behind the mark. Clean the tubes with denatured alcohol and glue the gun barrels in the wing with 6-minute epoxy. Position the guns so that they are parallel to the wing root.

Note: We have found that on some FW 190A-3's the wing did not have the gun covers on the top. On others only the two larger inner covers were installed and on some all four covers were installed. Two large and two small gun covers have been provided.

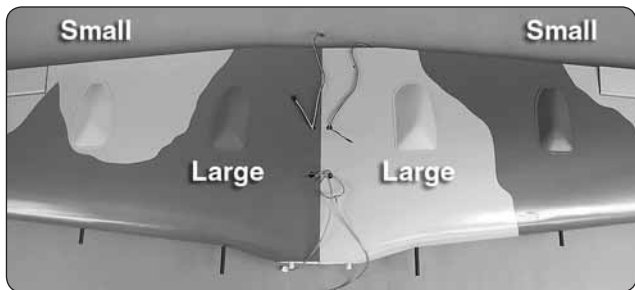

❑ 15. The gun covers are installed following the same method as the canopy. Draw the outline around the

covers. Use a T-pin to prick holes in the covering or remove the covering. Use canopy glue or epoxy to glue the covers to the wing.

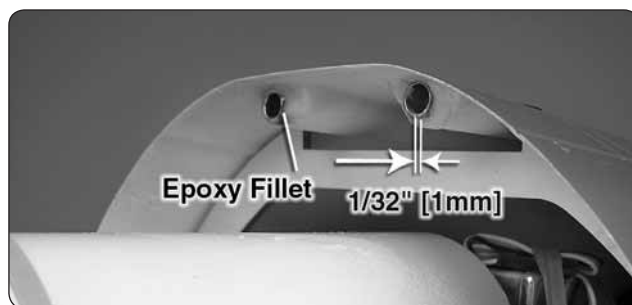
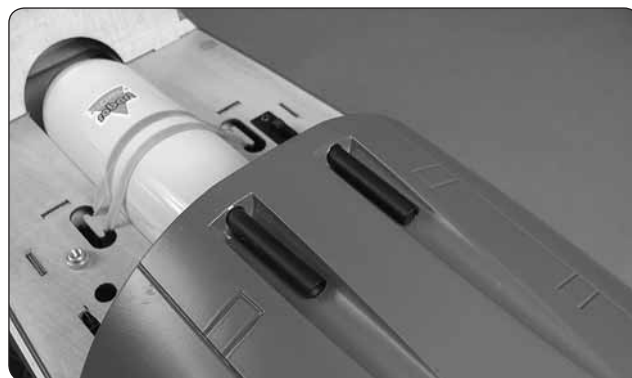

❑ 16. Use 6-minute epoxy to glue the two 1-3/4" [45mm] guns in the cowl. The guns should be positioned in the holes so that the top of the gun passes through by approximately 1/32" [1mm]. Once the epoxy has cured, position the cowl on its nose and apply a fillet of epoxy around the gun.



❑ 17. Trim the vertical fin antenna mount so that it sets flush on the leading edge of the fin. Drill a small hole in

the front of the mount. Insert a piece of elastic thread (not included) through the hole, make a knot on the end and glue it inside the antenna mount. Glue the mount to the top of the fin using the same method that was used to glue the canopy.



❑ 18. Trim the antenna mount for the top of the canopy leaving a 3/16" [4.8mm] lip around the mount. Use sandpaper to roughen the bottom of the antenna mount. Clean the bottom of the mount with denatured alcohol. Drill a small hole in the mount, insert the elastic thread, tie a knot and glue the thread to the inside of the mount. Use canopy glue to attach the mount to the top of the canopy, just behind the headrest.

❑ 19. Set the plane on its gear. From the front, view the plane from a few feet away. The wheels should be straight. If not, loosen the bolt in the retract that secures the main strut and adjust the wheels. Once satisfied, retract the gear and adjust the covers so that they are aligned with the bottom of the wing. Lower the retracts and apply a couple of drops of thin CA to the joint between the gear door mounts and the struts.



The Fw190s were modular designs. This permitted parts of the plane to be built by different manufacturers. All the parts could then be shipped to one location and assembled. It also allowed quick field repairs.

APPLY THE DECALS

- ❑ 1. The decals are die-cut from the factory.
- ❑ 2. Be certain the model is clean and free from oily fingerprints and dust. Prepare a dishpan or small bucket with a mixture of liquid dish soap and warm water—about 1/2 teaspoon of soap per gallon of water. Submerge one of the decals in the solution and peel off the paper backing. **Note:** Even though the decals have a “sticky-back” and are not the water transfer type, submersing them in soap & water allows accurate positioning and reduces air bubbles underneath.
- ❑ 3. Position decal on the model where desired. Holding the decal down, use a paper towel to wipe most of the water away.
- ❑ 4. Use a piece of soft balsa or something similar to squeegee remaining water from under the decal. Apply the rest of the decals the same way.

Please use the following pictures and the box top as a guide for the decal placement.

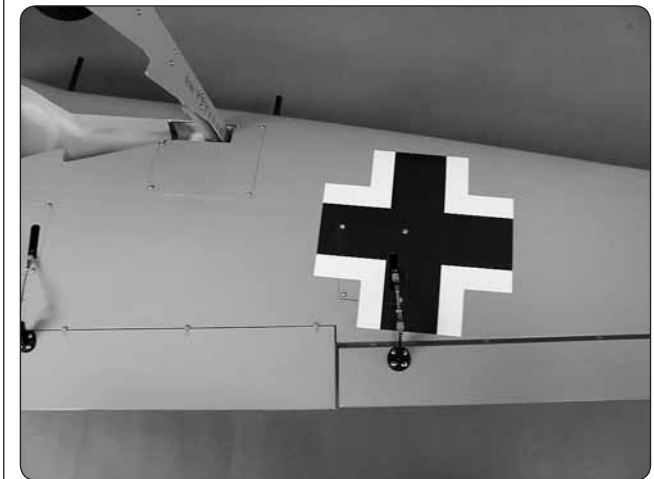
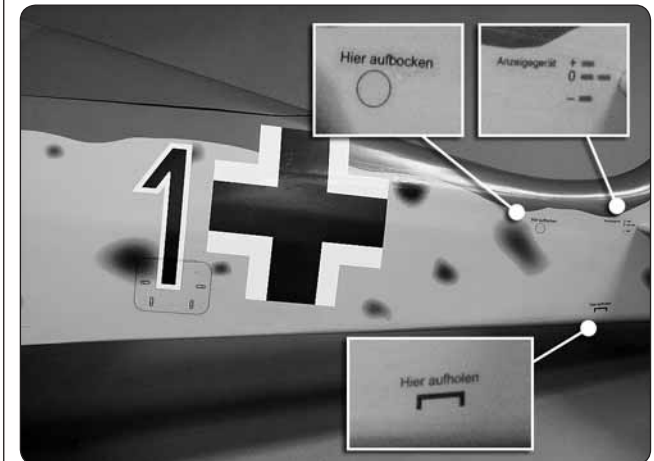
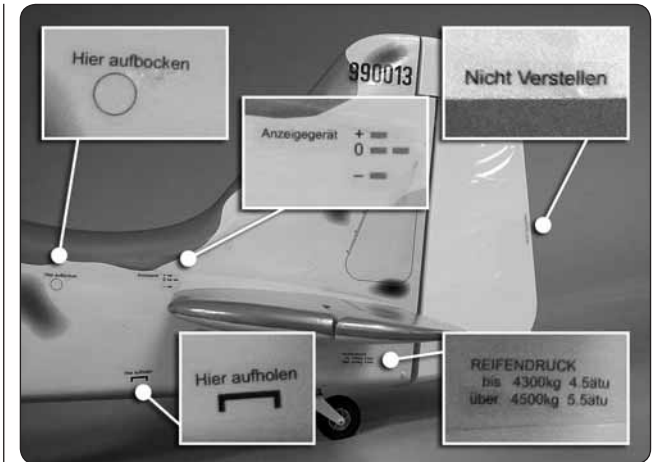
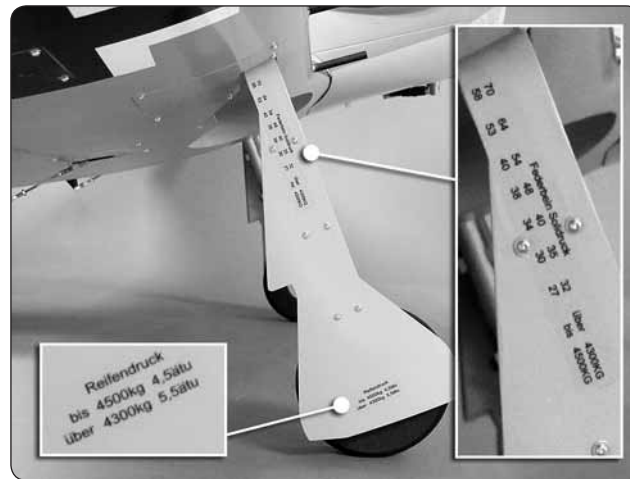
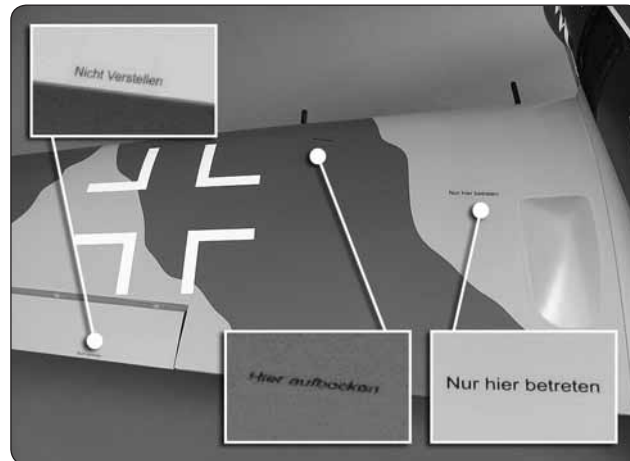
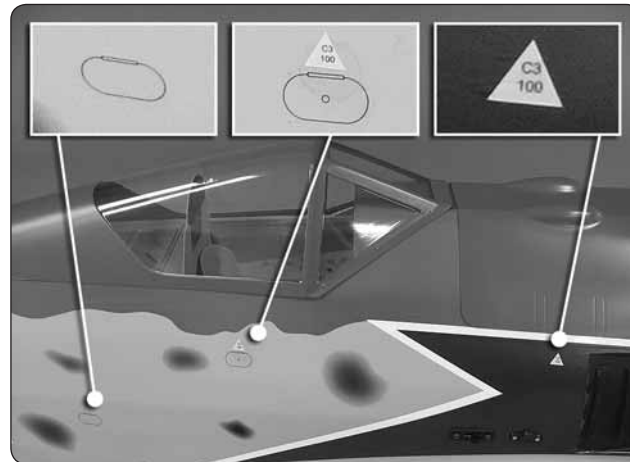
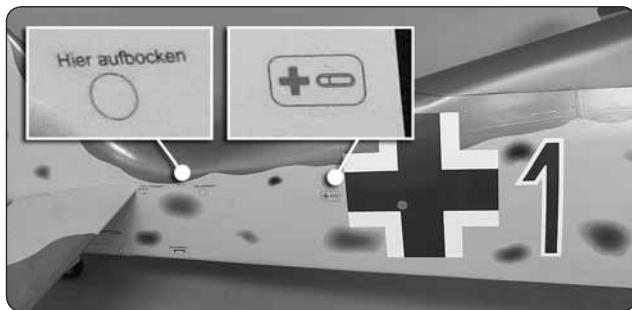
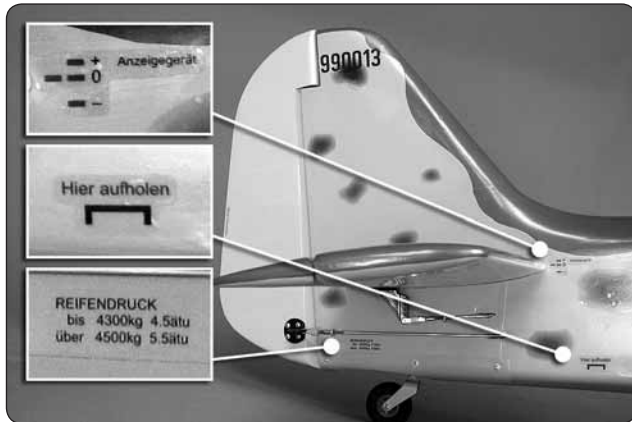

GET THE MODEL READY TO FLY

INSTALL THE PROPELLER

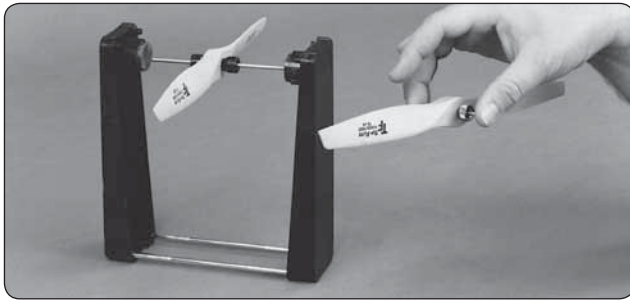

❑ 1. Carefully balance the propeller and any spare propellers. An unbalanced propeller can be the single most significant cause of vibration that can damage the model. Not only will engine mounting bolts loosen, possibly with disastrous effect, but vibration may also damage the receiver and receiver batteries. Vibration can also cause the fuel to foam, which will, in turn, cause the engine to run hot and quit.

We use a Top Flite Precision Magnetic Prop Balancer (TOPQ5700) in the workshop and keep a Great Planes Fingertip Prop Balancer (GPMQ5000) in our flight box.



❑ 2. The included aluminum spinner was designed to be used with the DA-50, DLE-55 and the O.S. GT55 gas engines. Drill the bolt holes through the propeller, slide the spinner backplate, propeller and prop washer on the engine prop shaft and install the prop bolts.

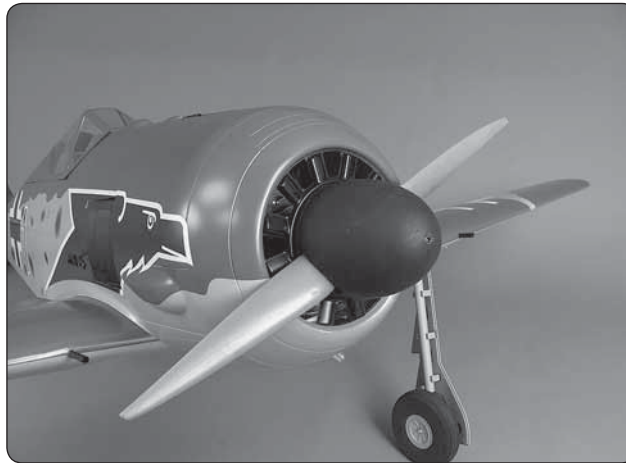

❑ 3. Install the spinner cone on the engine using an M5 x 85mm socket head cap screw. Use a drop of threadlocker on the threads. For a more realistic appearance Top Flite also offers a 3-bladed spinner (TOPA1882) for the 3-blade Zinger prop.

BALANCE THE MODEL Laterally

❑ 1. With the wing level, have an assistant help you lift the model by the engine propeller shaft and the bottom of the fuselage under the TE of the fin. Do this several times.

❑ 2. If one wing always drops when you lift the model, it means that side is heavy. Balance the airplane by adding weight to the other wing tip. **An airplane that has been laterally balanced will track better in loops and other maneuvers.**

CHECK THE CONTROL DIRECTIONS

❑ 1. Switch on the transmitter and receiver and center the trims. If necessary, remove the servo arms from the servos and reposition them so they are centered. Reinstall the screws that hold on the servo arms.

❑ 2. With the transmitter and receiver still on, check all the control surfaces to see if they are centered. If necessary, adjust the clevises on the pushrods to center the control surfaces.

4-CHANNEL RADIO SETUP (STANDARD MODE 2)

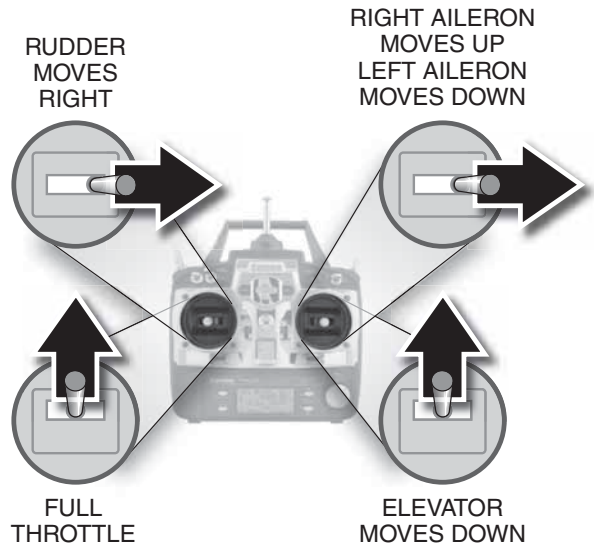

❑ 3. Make certain that the control surfaces and the carburetor respond in the correct direction as shown in the diagram. If any of the controls respond in the wrong direction, use the servo reversing in the transmitter to reverse the servos connected to those controls. Be certain the control surfaces have remained centered. Adjust if necessary.

SET THE CONTROL THROWS

To ensure a successful first flight, set up your Giant Fw 190A-3 ARF according to the control throws specified in this manual. The throws have been determined through actual flight testing and accurate record-keeping, allowing the model to perform in the manner in which it was intended. If, after you have become accustomed to the way the Giant Fw 190A-3 ARF flies, you would like to change the throws to suit your taste, that is fine. However, too much control throw could make the model too responsive and difficult to control, so remember, "more is not always better."

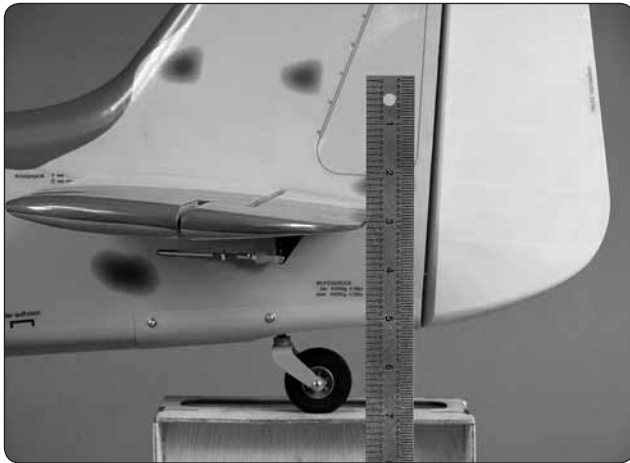

❑ 1. Use a box or something similar to prop up the bottom of the fuselage so the horizontal stabilizer and wing will be level. Hold a ruler vertically on your workbench against the widest part (front to back) of the trailing edge of the elevator. Note the measurement on the ruler.

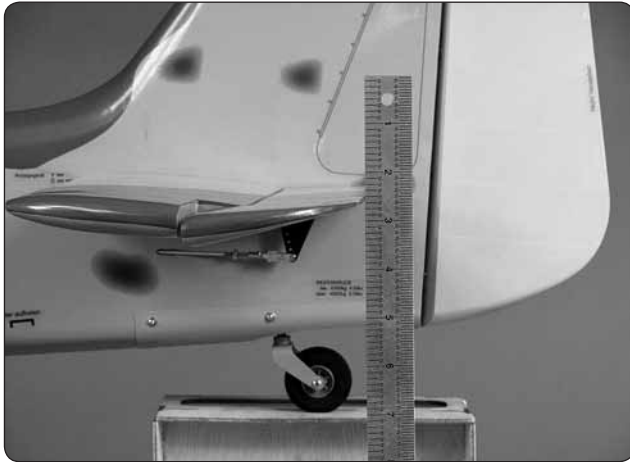

❑ 2. Measure the high rate elevator throw first. Move the elevator up with your transmitter and move the ruler forward so it will remain contacting the trailing edge. The distance the elevator moves up from center is the "up" elevator throw. Measure the down elevator throw the same way.

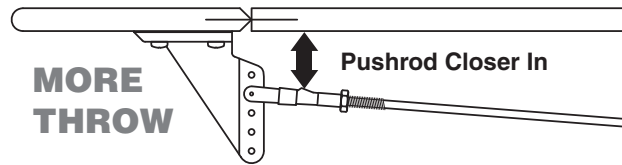
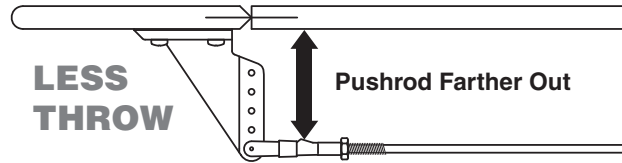

Pushrod Farther Out

Pushrod Closer In

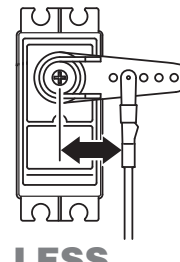
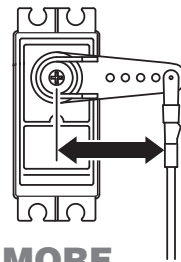

**MORE
THROW**

**LESS
THROW**

❑ 3. If necessary, adjust the location of the pushrod on the servo arm or on the elevator horn, or program the ATVs in your transmitter to increase or decrease the throw according to the measurements in the control throws chart.

❑ 4. Measure and set the **low rate** elevator throws and the high and low rate throws for the rest of the control surfaces the same way.

If your radio does not have dual rates, we recommend setting the throws at the high rate settings.

NOTE: The throws are measured at the **widest part** of the elevators, rudder and ailerons.

These are the recommended control surface throws:

	LOW RATE		HIGH RATE	
	Up	Down	Up	Down
ELEVATOR	5/16" [8mm] 8°	5/16" [8mm] 8°	7/16" [11mm] 11°	7/16" [11mm] 11°
RUDDER	Right 1-1/2" [38mm] 19°	Left 1-1/2" [38mm] 19°	Right 2" [51mm] 27°	Left 2" [51mm] 27°
AILERONS	Up 5/8" [16mm] 13°	Down 5/8" [16mm] 13°	Up 7/8" [22mm] 18°	Down 7/8" [22mm] 18°
FLAPS		2" [51mm] 35°		

BALANCE THE MODEL (C.G.)

More than any other factor, the C.G. (center of gravity/balance point) can have the greatest effect on how a model flies and could determine whether or not your first flight will be successful. If you value your model and wish to enjoy it for many flights, **DO NOT OVERLOOK THIS IMPORTANT PROCEDURE.** A model that is not properly balanced may be unstable and possibly unflyable.

At this stage the model should be in ready-to-fly condition with **all** of the components in place including the complete radio system, engine, muffler, propeller, spinner and pilot. The fuel tank should be empty.

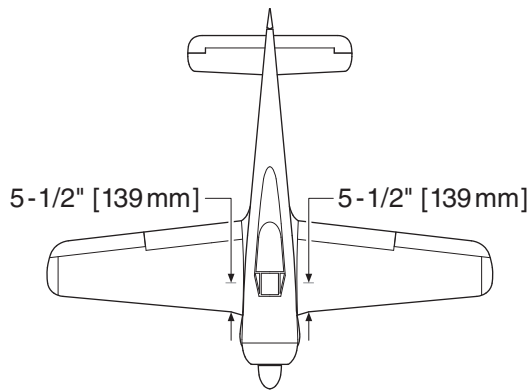

- ❑ 1. If using a Great Planes C.G. Machine™, set the rulers to 5-1/2" [139 mm]. If not using a C.G. Machine, use a fine-point felt tip pen to mark lines on the top of wing on both sides of the fuselage 5-1/2" [139 mm] back from the leading edge, at the leading edge "break" (or inboard guns). Apply narrow (1/16" [2mm]) strips of tape over the lines so you will be able to feel them when lifting the model with your fingers.

This is where your model should balance for the first flights. Later, you may experiment by shifting the C.G. 1/8" [4 mm] forward or 1/8" [4mm] back to change the flying characteristics. Moving the C.G. forward will improve the smoothness and stability, but the model will then be less aerobatic (which may be fine for less-experienced pilots). Moving the C.G. aft makes the model more maneuverable and aerobatic for experienced pilots. In any case, **start at the recommended balance point** and do not at any time balance the model outside the specified range.

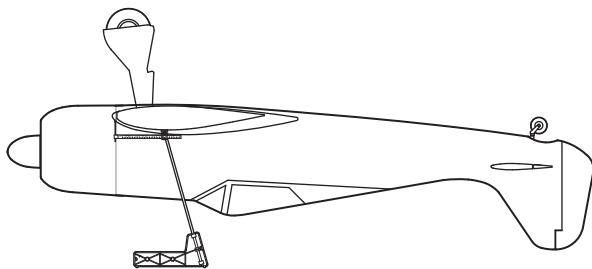

- ❑ 2. With the wing attached to the fuselage, all parts of the model installed (ready to fly) and an empty fuel

tank, place the model upside-down on a Great Planes CG Machine, or lift it upside-down at the balance point you marked.

- ❑ 3. If the tail drops, the model is "tail heavy." If the nose drops, the model is "nose heavy." Use Great Planes "stick-on" lead (GPMQ4485) to balance the plane. To find out how much weight is required, place incrementally increasing amounts of weight on the bottom of the fuselage over the location where it would be mounted inside until the model balances. A good place to add stick-on nose weight is to the firewall. Do not attach weight to the cowl—this will cause stress on the cowl and could cause the cowl ring to break loose from the cowl. **Note:** The manufacturer has already installed some weight on the firewall. If the plane is nose heavy, start by removing some of the pre-installed nose weight before adding tail weight. Once you have determined if additional weight needs to be installed, it can be permanently attached.

Do not rely upon the adhesive on the back of the lead weight to permanently hold it in place. Over time, fuel vibration and exhaust residue may soften the adhesive and cause the weight to fall off. Instead, permanently attach the weight with glue or screws.

Note: It is highly recommended that with gas powered planes the ignition system and all its components be separated from the radio system components by at least 10" [254mm] to prevent ignition noise from interfering with the radio system. If the plane is tail heavy, do not move the receiver battery forward closer to the ignition system. If the plane is nose heavy, do not move the ignition battery aft closer to the receiver.

- ❑ 4. **IMPORTANT:** If you found it necessary to add any weight, recheck the C.G. after the weight has been installed.

CHECK LIST

During the last few moments of preparation your mind may be elsewhere anticipating the excitement of the first flight. Because of this, you may be more likely to overlook certain checks and procedures that should be performed before the model is flown. To help avoid this, a check list is provided to make sure these important areas are not overlooked. Many are covered in the instruction manual, so where appropriate, refer to the manual for complete instructions. Be sure to check the items off as they are completed (that's why it's called a *check list!*).

- ❑ 1. Fuelproof all areas exposed to fuel or exhaust residue such as the cowl ring, wing saddle area, etc.
- ❑ 2. Check the C.G. according to the measurements provided in the manual.
- ❑ 3. Be certain the battery and receiver are securely mounted in the fuse. Simply stuffing them into place with foam rubber is not sufficient.
- ❑ 4. If you still fly on 72MHz, extend your receiver antenna and make sure it has a strain relief inside the fuselage to keep tension off the solder joint inside the receiver.
- ❑ 5. Balance your model *laterally* as explained in the instructions.
- ❑ 6. Use threadlocking compound to secure critical fasteners such as the set screws that hold the wheel axles to the struts, screws that hold the carburetor arm (if applicable), engine bolts, etc.
- ❑ 7. Add a drop of oil to the axles so the wheels will turn freely.
- ❑ 8. Give the control surfaces a quick tug to make sure all hinges are **securely** glued in place.
- ❑ 9. Reinforce holes for wood screws with thin CA where appropriate (servo mounting screws, aileron hatches, etc.).
- ❑ 10. Confirm that all controls operate in the correct direction and the throws are set up according to the manual. Checking the direction should be performed

before every flight. With computer radios it is easy to mistakenly change the model.

- 11. Make sure there are silicone retainers on all the clevises and that all servo arms are secured to the servos with the screws included with your radio.
- 12. Secure connections between servo wires and Y-connectors or servo extensions, and the connection between your battery pack and the on/off switch with vinyl tape, heat shrink tubing or special clips suitable for that purpose.
- 13. Make sure any servo extension cords and air lines you may have used do not interfere with other systems (servo arms, pushrods, etc.).
- 14. Make sure the fuel lines are connected and are not kinked.
- 15. Balance your propeller (and spare propellers).
- 16. Check that the spinner bolt is tight.
- 17. Place your name, address, AMA number and telephone number on or inside your model. This is an AMA rule.
- 18. Cycle your receiver and ignition battery pack (if necessary) and make sure it is fully charged.
- 19. If you wish to photograph your model, do so before your first flight.
- 20. Range check your radio when you get to the flying field.

PREFLIGHT

IDENTIFY YOUR MODEL

No matter if you fly at an AMA sanctioned R/C club site or if you fly somewhere on your own, you should always have your name, address, telephone number and AMA number on or inside your model. It is **required** at all AMA R/C club flying sites and AMA sanctioned flying events. Fill out the identification tag on page 35 and place it on or inside your model.

CHARGE THE BATTERIES

Follow the battery charging instructions that came with your radio control system to charge the batteries. You

should always charge your transmitter and receiver batteries the night before you go flying, and at other times as recommended by the radio manufacturer.

CAUTION: Unless the instructions that came with your radio system state differently, the **initial** charge on **new** transmitter and receiver batteries should be done for 15 hours **using the slow-charger that came with the radio system**. This will “condition” the batteries so that the next charge may be done using the fast-charger of your choice. If the initial charge is done with a fast-charger the batteries may not reach their full capacity and you may be flying with batteries that are only partially charged.

GROUND CHECK AND RANGE CHECK

Run the engine for a few minutes to make sure it idles reliably, transitions smoothly and maintains full power indefinitely. Afterward, shut the engine off and inspect the model closely, making sure all fasteners, pushrods and connections have remained tight and the hinges are secure. Always ground check the operational range of your radio before the first flight of the day following the manufacturer’s instructions that came with your radio. This should be done once with the engine off and once with the engine running at various speeds. If the control surfaces do not respond correctly, **do not fly!** Find and correct the problem first. Look for loose servo connections or broken wires, corroded wires on old servo connectors, poor solder joints in your battery pack or a defective cell, or a damaged receiver crystal from a previous crash.

ENGINE SAFETY PRECAUTIONS

Failure to follow these safety precautions may result in severe injury to yourself and others.

Keep all engine fuel in a safe place, away from high heat, sparks or flames, as fuel is very flammable. Do not smoke near the engine or fuel; and remember that engine exhaust gives off a great deal of deadly carbon monoxide. Therefore **do not run the engine in a closed room or garage.**

Get help from an experienced pilot when learning to operate engines.

Use safety glasses when starting or running engines.

Use a “chicken stick” or electric starter to start the engine. If you do flip the propeller with your fingers, wear a heavy leather glove, such as a welders glove. When hand starting gas engines, if the engine should backfire, the large prop can cause severe injury to your hand and fingers.

Do not run the engine in an area of loose gravel or sand; the propeller may throw such material in your face or eyes.

Keep your face and body as well as all spectators away from the plane of rotation of the propeller as you start and run the engine.

Keep these items away from the prop: loose clothing, shirt sleeves, ties, scarfs, long hair or loose objects such as pencils or screwdrivers that may fall out of shirt or jacket pockets into the prop.

Stop the engine before making any engine adjustments.

The engine and muffler get hot! Do not touch them during or right after operation. Make sure fuel lines are in good condition so fuel will not leak onto a hot engine, causing a fire.

To stop a gasoline powered engine an on/off switch must be connected to the engine ignition. Do not throw anything into the propeller of a running engine.

AMA SAFETY CODE

Read and abide by the following excerpts from the Academy of Model Aeronautics Safety Code. For the complete Safety Code refer to *Model Aviation* magazine, the AMA web site or the Code that came with your AMA license.

GENERAL

1) I will not fly my model aircraft in sanctioned events, air shows, or model flying demonstrations until it has been proven to be airworthy by having been previously, successfully flight tested.

2) I will not fly my model aircraft higher than approximately 400 feet within 3 miles of an airport without notifying the airport operator. I will give right-of-way and avoid flying in the proximity of full-scale aircraft. Where necessary, an observer shall be utilized to supervise flying to avoid having models fly in the proximity of full-scale aircraft.

3) Where established, I will abide by the safety rules for the flying site I use, and I will not willfully and deliberately fly my models in a careless, reckless and/or dangerous manner.

5) I will not fly my model unless it is identified with my name and address or AMA number, on or in the model. Note: This does not apply to models while being flown indoors.

7) I will not operate models with pyrotechnics (any device that explodes, burns, or propels a projectile of any kind).

RADIO CONTROL

1) I will have completed a successful radio equipment ground check before the first flight of a new or repaired model.

2) I will not fly my model aircraft in the presence of spectators until I become a qualified flier, unless assisted by an experienced helper.

3) At all flying sites a straight or curved line(s) must be established in front of which all flying takes place with the other side for spectators. Only personnel involved with flying the aircraft are allowed at or in the front of the flight line. Intentional flying behind the flight line is prohibited.

4) I will operate my model using only radio control frequencies currently allowed by the Federal Communications Commission.

5) **I will not knowingly operate my model within three miles of any pre-existing flying site except in accordance with the frequency sharing agreement listed [in the complete AMA Safety Code].**

9) Under no circumstances may a pilot or other person touch a powered model in flight; **nor should any part of the model other than the landing gear, intentionally touch the ground, except while landing.**

Since the Giant FW 190A-3 ARF qualifies as a “giant scale’ model and is therefore eligible to fly in IMAA events, we’ve printed excerpts from the IMAA Safety Code which follows.

IMAA SAFETY CODE

DEFINITION: For the purpose of the following IMAA Safety Code, the term Giant Scale shall refer to radio controlled model aircraft, either scale or non-scale, which have a wingspan of 80 inches [2032mm] or more for monoplanes and 60 inches [1524mm] or more for multi-winged model aircraft and have a ramp weight (fueled and ready to fly) of 55lbs. [24.75kg.] or less.

Section 1.0: Safety Standard

- 1.1 Adherence to Code: This safety code is to be strictly followed.
- 1.2 The most current AMA Safety Code in effect is to be observed. However, the competition sections of the code may be disregarded.

Section 3.0 Safety Check

- 3.4 Flight Testing: All Giant Scale R/C aircraft are to have been flight tested and flight trimmed with a minimum of six flights before the model is allowed to fly at an IMAA Sanctioned event.
- 3.5 Proof of Flight: The completing and signing of the Declaration section of the Safety Inspection form by the pilot (or owner) shall document as fact that each aircraft has been successfully flight-tested and proven airworthy prior to an IMAA event.

Section 5.0: Emergency Engine Shut Off (Kill Switch)

- 5.1 All magneto spark ignition engines must have a coil grounding switch on the aircraft to stop the engine. This will also prevent accidental starting of the engine. This switch shall be readily available to both pilot and helper. This switch is to be operated manually and without the use of the radio system.
- 5.2 Engine with battery power ignition systems must have a switch to turn off the power from the battery pack to disable the engine from firing. This will also prevent accidental starting of the engine. This switch shall be readily available to both pilot and helper. This switch shall be operated manually and without the use of the radio system.

5.3 There must also be a means to stop the engine from the transmitter. The most common method is to close the carburetor throat completely using throttle trim. However, other methods are acceptable. This requirement applies to all glow/gas ignition engines regardless of size.

Section 6.0: Radio Requirements

- 6.1 All transmitters must be FCC type certified.
- 6.2 FCC Technician or high-class license required for 6 meter band operation only.

Additional IMAA General Recommendations

The following recommendations are included in the Safety Code not to police such items, but rather to offer basic suggestions for enhanced safety.

Servos need to be of a rating capable to handle the loads that the control surfaces impose upon the servos. Standard servos are not recommended for control surfaces. Servos should be rated heavy-duty. For flight-critical control functions a minimum of 45 inch/ounces of torque should be considered. This should be considered a minimum for smaller aircraft and higher torque servos are strongly encouraged for larger aircraft. The use of one servo for each aileron and one for each elevator half is strongly recommended. Use of dual servos is also recommended for larger aircraft.

On-board batteries shall be 1000 mAh up to 20 lbs., 1200 mAh to 30 lbs., 1800 mAh to 40 lbs. and 2000 mAh over 40 lbs. flying weight. The number and size of the servos, size and loads on control surfaces, and added features should be considered as an increase to these minimums. Batteries should be able to sustain power to the onboard radio components for a minimum of one hour total flying time before recharging.

Both redundant and fail-safe battery systems are recommended.

There is no minimum engine displacement limit, as it is the position of this body that an underpowered aircraft presents a greater danger than an overpowered aircraft. However, the selection of engine size relative to airframe strength and power loading mandates good discretionary judgment by the designer and builder.

Current AMA maximums for engine displacement are 6.0 cu. in. for two-stroke and 9.6 cu. in. for four-stroke engine. These maximums apply only to AMA Sanctions concerning competition events (such as 511, 512, 515 and 520) and, as such, the maximums apply. All IMAA (non competition) events should be sanctioned as Class "C" events, in which these engine size maximums do not apply.

Generally, it is recommended that no attempt should be made to fly a radio controlled model aircraft with a gasoline engine in which the model aircraft weight would exceed twelve (12) pounds (underpowered) per cubic inch of engine displacement, or be less than five (5) pounds (overpowered) per cubic inch of engine displacement. Example: Using a 3 cu. in. engine, a model would likely be underpowered at an aircraft weight greater than 36 pounds. With the same engine, an aircraft weighing less than 15 pounds would likely be overpowered.

Servo arms and wheels should be rated heavy duty. Glass-filled servo arms and control horns are highly recommended.

Propeller tips should be painted or colored in a visible and contrasting manner so as to increase the visibility of the propeller tip arc.

FLYING

The Giant FW 190A-3 ARF is a great-flying model that flies smoothly and predictably. The Giant FW 190A-3 ARF does not, however, possess the self-recovery characteristics of a primary R/C trainer and should be flown only by experienced R/C pilots.

FUEL MIXTURE ADJUSTMENTS

A fully cowled engine may run at a higher temperature than an un-cowled engine. For this reason, the fuel mixture should be richened so the engine runs at about 200 rpm below peak speed. By running the engine slightly rich, you will help prevent dead-stick landings caused by overheating.

CAUTION (THIS APPLIES TO ALL R/C AIRPLANES):

If, while flying, you notice an alarming or unusual sound such as a low-pitched "buzz," this may indicate control surface *flutter*. Flutter occurs when a control surface (such as an aileron or elevator) or a flying surface (such as a wing or stab) rapidly vibrates up and down (thus causing the noise). In extreme cases, if not detected immediately, flutter can actually cause the control surface to detach or the flying surface to fail, thus causing loss of control followed by an impending crash. The best thing to do when flutter is detected is to slow the model **immediately** by reducing power, then land as soon as safely possible. Identify which surface fluttered (so the problem may be resolved) by checking all the servo grommets for deterioration or signs of vibration. Make certain all pushrod linkages are secure and free of play. If it fluttered once, under similar circumstances it will probably flutter again unless the problem is fixed. Some things which can cause flutter are; Excessive hinge gap; Not mounting control horns solidly; Poor fit of clevis pin in horn; Side-play of wire pushrods caused by large bends; Excessive free play in servo gears; Insecure servo mounting; and one of the most prevalent causes of flutter; Flying an over-powered model at excessive speeds.

TAKEOFF

Before you get ready to takeoff, see how the model handles on the ground by doing a few practice runs at **low speeds** on the runway. Hold "up" elevator to keep the tail wheel on the ground. If necessary, adjust the tail wheel so the model will roll straight down the runway. If you need to calm your nerves before the maiden flight, shut the engine down and bring the model back into the pits. Top off the fuel, then check all fasteners and control linkages for peace of mind.

Remember to takeoff into the wind. When you're ready, point the model straight down the runway, hold a bit of up elevator to keep the tail on the ground to maintain tail wheel steering, then gradually advance the throttle. As the model gains speed, decrease up elevator allowing the tail to come off the ground. One of the most important

things to remember with a tail dragger is to always be ready to apply **right** rudder to counteract engine torque. Gain as much speed as your runway and flying site will practically allow before gently applying up elevator, lifting the model into the air. At this moment it is likely that you will need to apply more right rudder to counteract engine torque. Be smooth on the elevator stick, allowing the model to establish a **gentle** climb to a safe altitude before turning into the traffic pattern.

FLIGHT

For reassurance and to keep an eye on other traffic, it is a good idea to have an assistant on the flight line with you. Tell him to remind you to throttle back once the plane gets to a comfortable altitude. While full throttle is usually desirable for takeoff, most models fly more smoothly at reduced speeds.

Take it easy with the Giant FW 190A-3 ARF for the first few flights, gradually getting acquainted with it as you gain confidence. Adjust the trims to maintain straight and level flight. After flying around for a while, and while still at a safe altitude with plenty of fuel, practice slow flight and execute practice landing approaches by reducing the throttle and lowering the flaps to see how the model handles at slower speeds. Add power to see how she climbs as well. Continue to fly around, executing various maneuvers and making mental notes (or having your assistant write them down) of what trim or C.G. changes may be required to fine tune the model so it flies the way you like. Mind your fuel level, but use this first flight to become familiar with your model before landing.

LANDING

One of the keys to landing a giant-scale model is to maintain sufficient airspeed throughout the landing approach. An unusually high airspeed is not necessary, but those unfamiliar with landing giant-scale models are sometimes deceived by the model's larger size. Larger models often appear to be closer than they actually are. Additionally, most giant-scale models slow down rapidly, thus causing the uninitiated to land short. To avoid this initial illusion, make your landing pattern closer than you normally might for a .40-size sport model. Also, don't pull the throttle all the way back and leave it there the

way you normally would. Instead, momentarily pull the throttle all the way back, but then advance it a “click” or two to keep the engine RPM up and maintain airspeed. Once over the runway you can cut the throttle the rest of the way and the model will slow for the landing flare.

The Giant FW 190A-3 ARF may be landed with or without flaps. Flaps increase lift and drag, so the plane may be landed slower, thus reducing rollout after touchdown (not as much of a factor on grass runways). To initiate a landing approach, lower the throttle while on the downwind leg. If using flaps, allow the model to slow before extending them. Continue to lose altitude, but maintain airspeed by keeping the nose down as you turn onto the crosswind leg. Make your final turn toward the runway (into the wind) keeping the nose down to maintain airspeed and control. If using flaps, keep a few additional “clicks” of power so the model doesn’t slow too much. Level the attitude when the model reaches the runway threshold, modulating the throttle as necessary to maintain your glide path and airspeed. If you are going

to overshoot, smoothly advance the throttle (always ready on the right rudder to counteract torque) and retract the flaps when enough airspeed is gained. Climb out to make another attempt. When the model is a foot or so off the deck, smoothly increase up elevator until it gently touches down. Once the model is on the runway and has lost flying speed, hold up elevator to place the tail on the ground, regaining tail wheel control.

Note: If ever the occasion arises when a dead-stick landing must be performed, do not extend the flaps until **certain** the model will be able to reach the landing zone (on dead-stick landings it is common to land with no flaps at all). Without engine power, flaps can unexpectedly reduce the model’s range, thus causing you to come up short of the field.

One final note about flying your Giant FW 190A-3 ARF. Have a goal or flight plan in mind for **every** flight. This can be learning a new maneuver(s), improving a maneuver(s) you already know, or learning how the

model behaves in certain conditions (such as on high or low rates). This is not necessarily to improve your skills (*though it is never a bad idea!*), but more importantly so you do not surprise yourself by impulsively attempting a maneuver and suddenly finding that you’ve run out of time, altitude or airspeed. Every maneuver should be deliberate, not impulsive. For example, if you’re going to do a loop, check your altitude, mind the wind direction (anticipating rudder corrections that will be required to maintain heading), remember to throttle back at the top, and make certain you are on the desired rates (high/low rates). A flight plan greatly reduces the chances of crashing your model just because of poor planning and impulsive moves. **Remember to think.**

Have a ball! But always stay in control and fly in a safe manner.

GOOD LUCK AND GREAT FLYING!

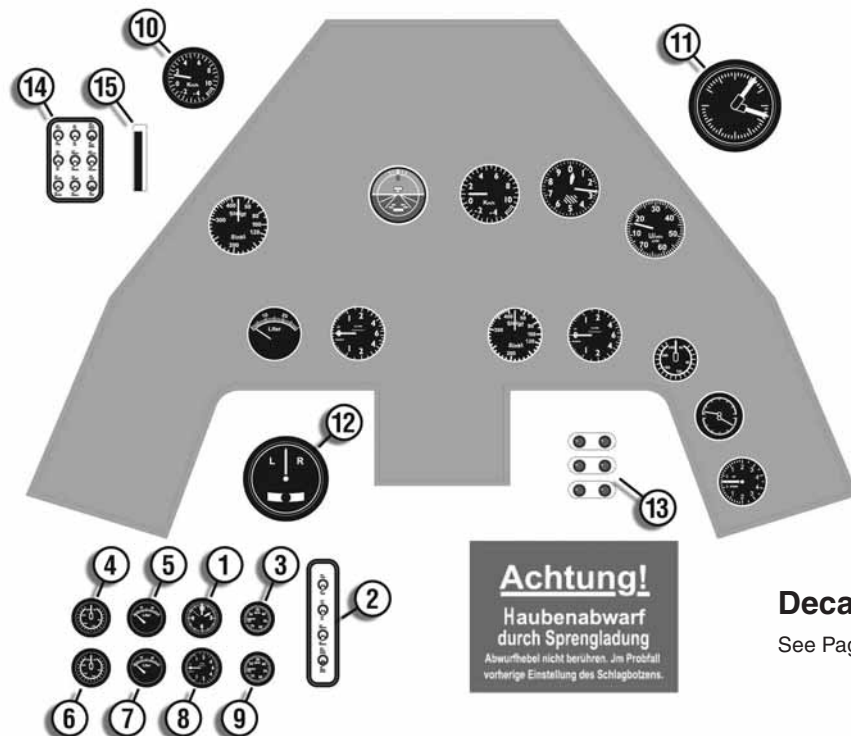

Decal Placement Key

See Page 24.

HOW TO MAKE AN EXTENDED 7/64" BALL WRENCH

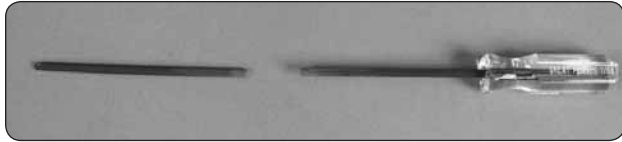

1. Cut the 7/64" ball wrench in approximately equal parts.

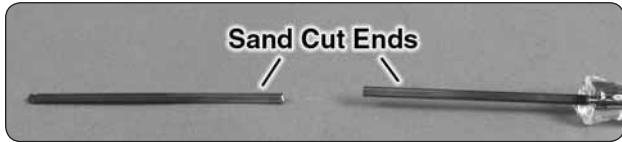

2. Use a piece of sandpaper to remove the coating from the wrench 1-1/2" (38mm) from the cut.

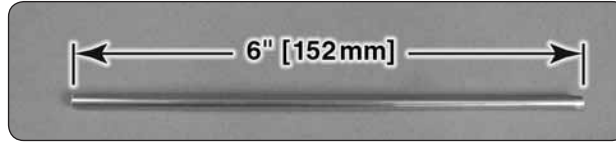

3. Cut a piece of 5/32" x .014 (3.9 x .3mm) round brass tube 6" (152mm) long.

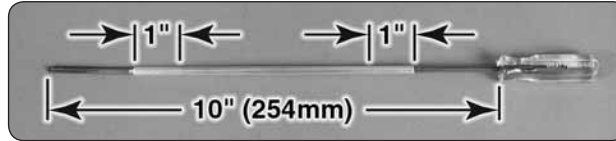

4. Clean the ball wrench with denatured alcohol. Apply silver solder flux to the cut ends of the ball wrench and

the inside of the brass tube. Slide the cut ends of the wrench into the brass tube 1" (25.4mm). Heat the tube and the ball wrench and use silver solder to join the pieces together. The length of the wrench needs to be 10" (254mm) long to reach the bolts inside the cowl.

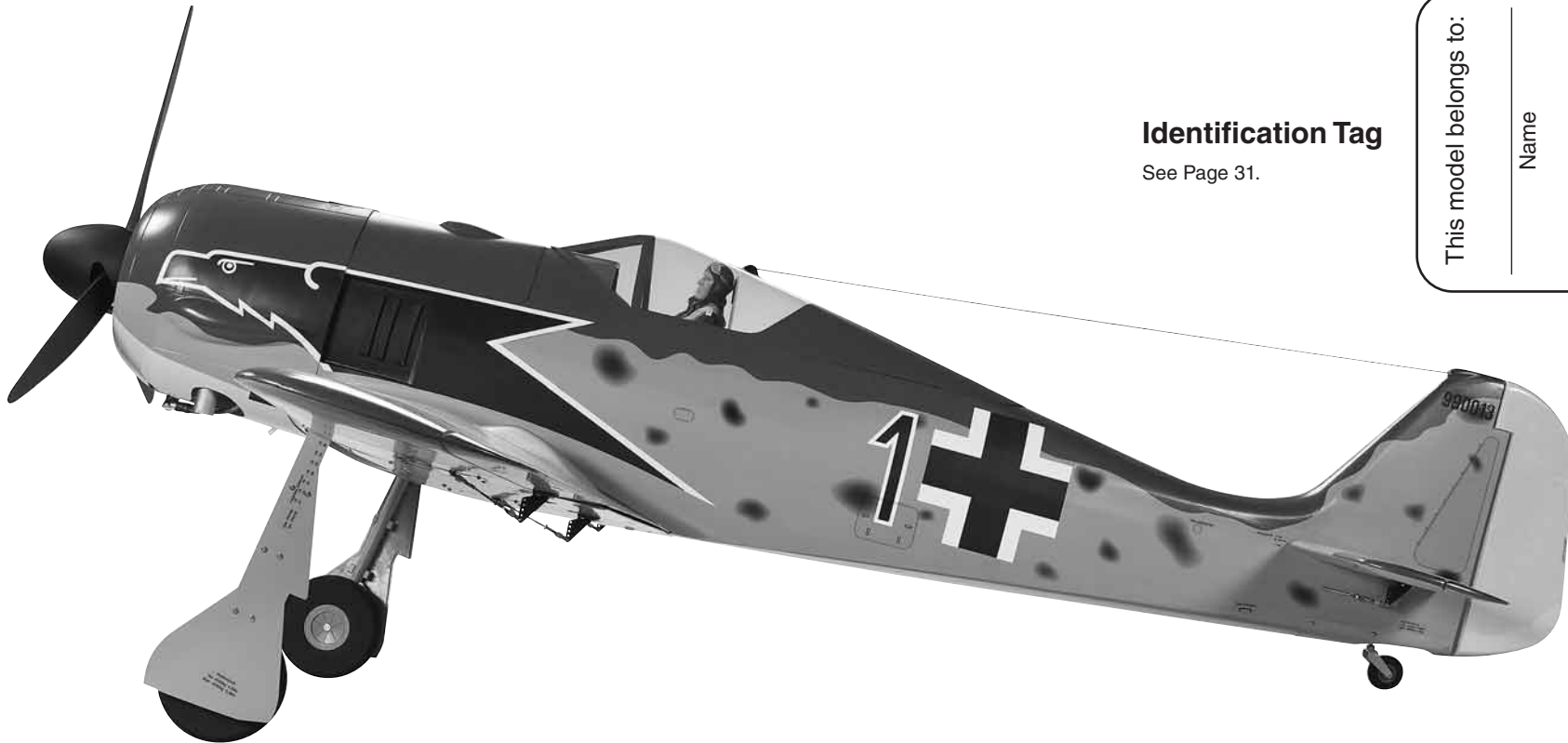

Identification Tag

See Page 31.

This model belongs to:

Name

Address

City, State, Zip

Phone Number

AMA Number

